

Red Thumb LED Flash Lamp DIY Kit

1.Introduction:

It is a simple mini Red Thumb LED Flash Lamp DIY kit. The circuit is controlled by a DX158 LED driver chip, which can achieve automatic switching and cyclic playback of multifunctional light flashing modes after power ON. The flashing speed of the LED can also be adjusted by pressing the button.

2.Feature:

- 1>.Red LED Flashing
- 2>.Automatic Switch Flashing Effect
- 3>.Adjustable LED Flashing Speed
- 4>.DC-003 5V Power Supply
- 5>.DIY Manual Soldering

3.Parameter:

- 1>.Work Voltage:DC 5V
- 2>.Power Type: DC-003 Socket
- 3>.LED Color: 81pcs Red
- 4>.Work Temperature:-40℃~85℃
- 5>.Work Humidity:5%~95%RH
- 6>.Size(Installed):77*75*9mm

4.Use Methods:

- 1>.Input 5V work voltage from DC-003 Power Socket. Note:Users need to prepare their own USB-DC003 power cord.
- 2>.Turn Toggle Switch to ON/OFF work power.
- 3>.Press Black Button to increase LED Flashing Speed. Note: the speed will switch to the lowest speed if you continue to press the button, when reaching the maximum speed.
- 4>.Note: There is no memory function for speed, and every time the power is restarted, the speed needs to be readjusted.

5.Component Listing:

- 1>.1pcs SOP-16 DX158 LED Driver Controller
- 2>.1pcs DC-003 Power Socket
- 3>.1pcs 6*6mm Black Button
- 4>.1pcs SS-12D07 Toggle Switch
- 5>.81pcs 4mm Red LED
- 6>.1pcs 77*75mm PCB Circuit Board

6.Application:

- 1>.Christmas decorations Training welding skills
- 2>.Training welding skills
- 3>.Student school
- 4>.Project Design
- 5>.Electronic competition
- 6>.Gift giving
- 7>.Crafts collection
- 8>.Home decoration
- 9>.Souvenir collection
- 10>.Graduation design
- 11>.Holiday gifts

7.Installation Tips:

- 1>.User needs to prepare the welding tool at first.
 - 1.1>.Soldering iron (<50 Watt)
 - 1.2>.Rosin core ("radio") solder
 - 1.3>.Wire cutters
 - 1.4>.Wire strippers
 - 1.5>.Screwdriver
- 2>.Please be patient until the installation is complete.
- 3>.The package is DIY kit.It need finish install by user.

4>.The soldering iron can't touch the components for a long time(1.0 second), otherwise it will damage the components.

5>.Pay attention to the positive and negative of the components.

6>.Strictly prohibit short circuit.

7>.User must install the LED according to the specified rules.Otherwise some LED will not light.

8>.Install complex components preferentially.

9>.Make sure all components are in right direction and right place.

10>.It is strongly recommended to read the installation manual before starting installation!!!

11>.Please wear anti-static gloves or anti-static wristbands when installing electronic components.

8.Installation Steps(Please be patient install!!!):

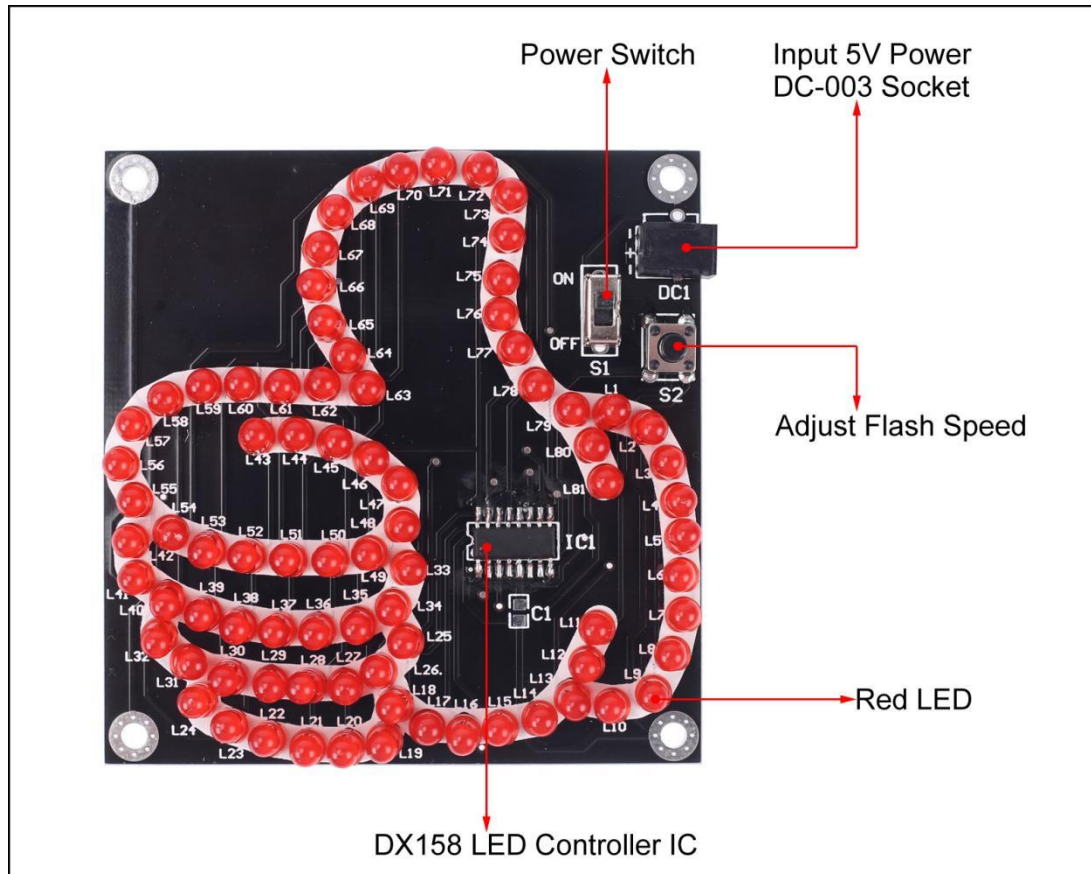

Step 1: Install 1pcs SMD components SOP-16 DX158 FM Receiver at IC1.
Verify and confirm the installation direction of DX158. There is a dot mark on one end of the IC and there is a white dot mark on PCB silk screen where the IC can place on. These two marks are corresponding to each other and are used to specify the installation direction of the IC.

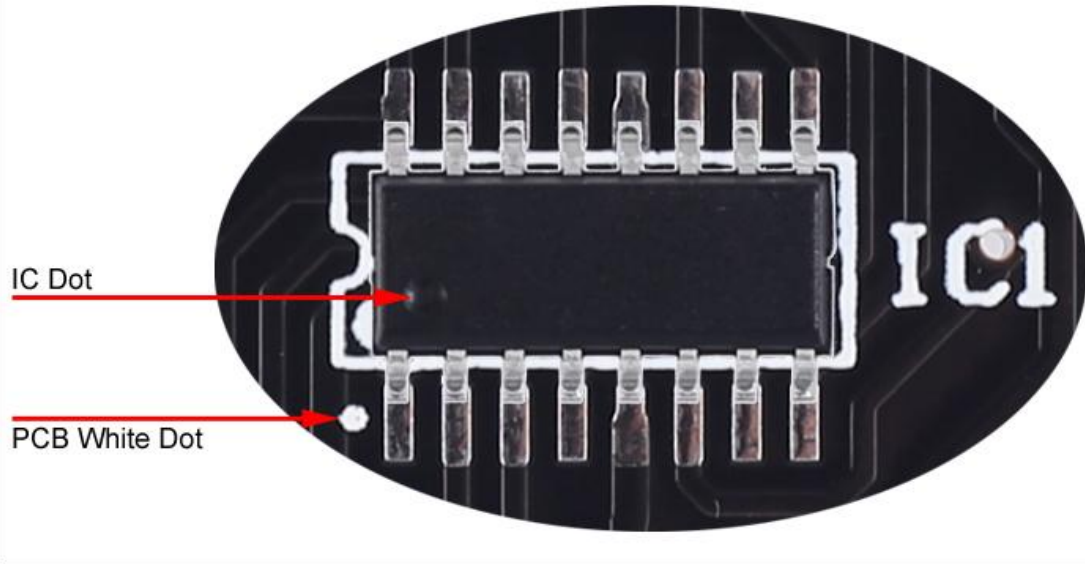

Step 2: Randomly choose a pad on the PCB, and then melt the solder on this pad.

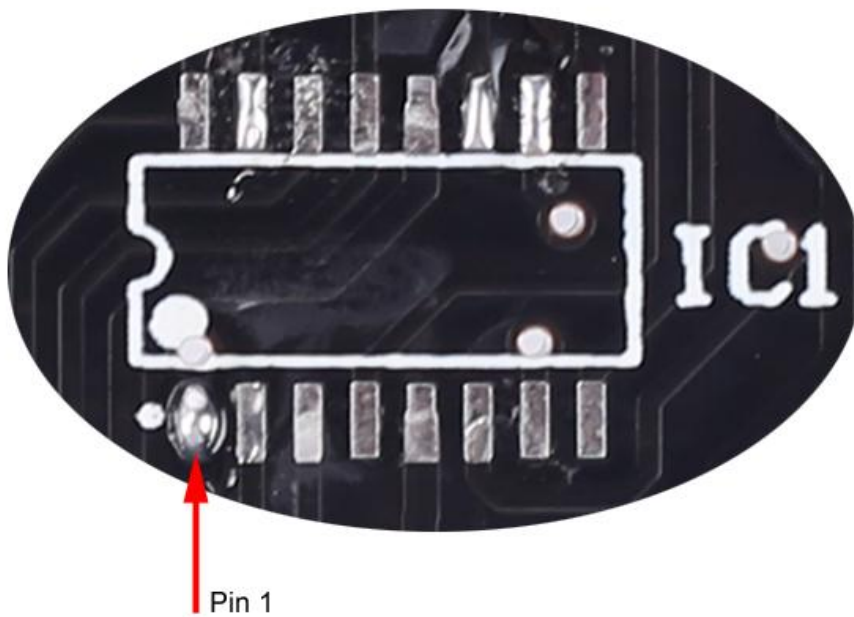

Step 3: Fix DX158: Use a soldering iron to melt tin on the pad just now and hold DX158 with tweezers in the other hand to place/press on IC1 to prevent movement. Take care to match and align each pads. Then remove soldering iron. Then remove tweezers after solder tin cooling and solidification.

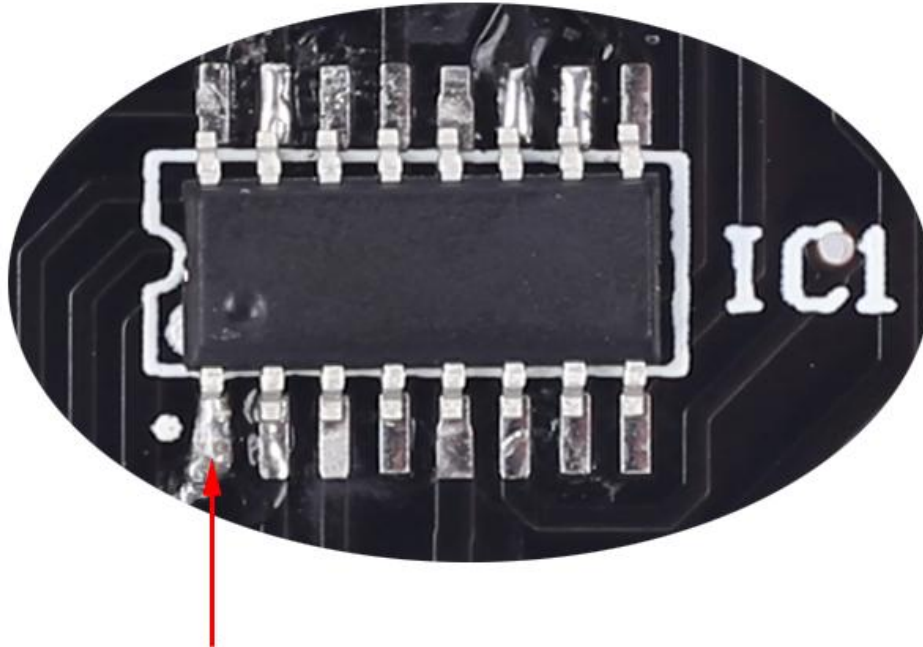

Step 4: Connect others pads on DX158 to pads on PCB by tin and soldering iron.

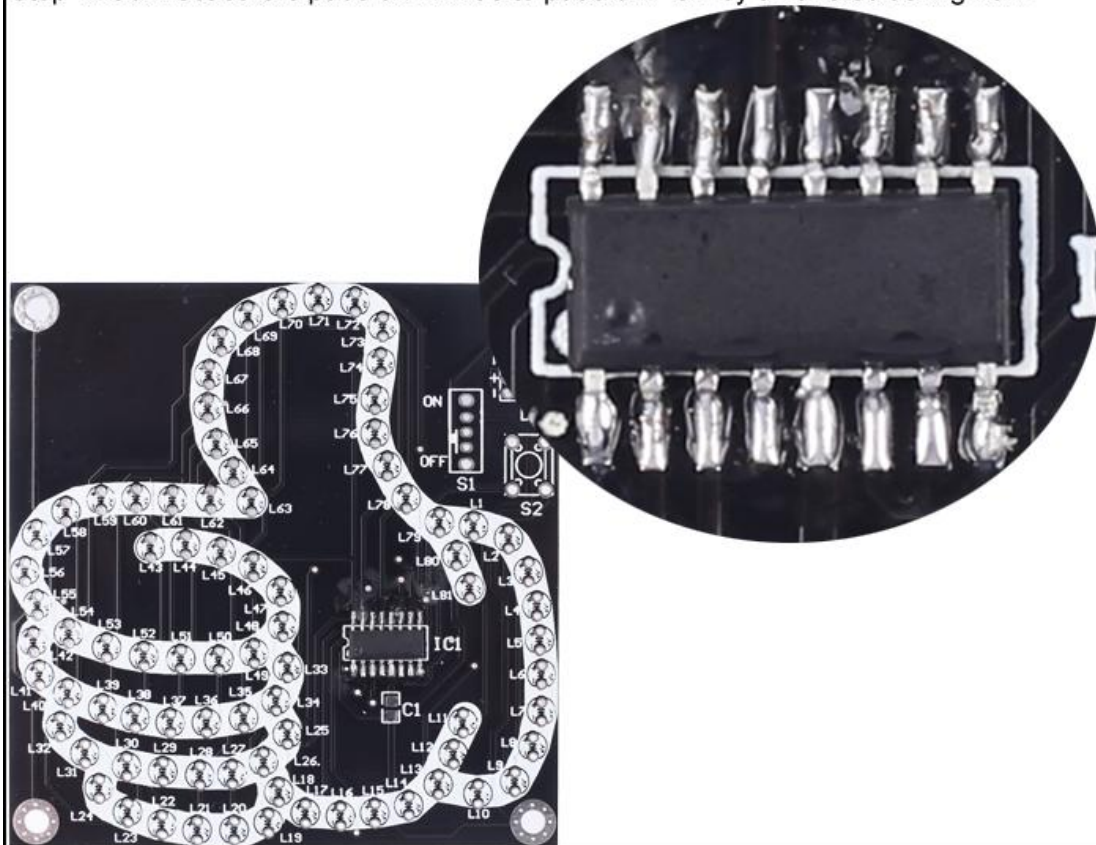

Step 5: Install 81pcs 4mm Red LED at L1-L81.
Note: the shorter pin connect to '-' pad as shown.

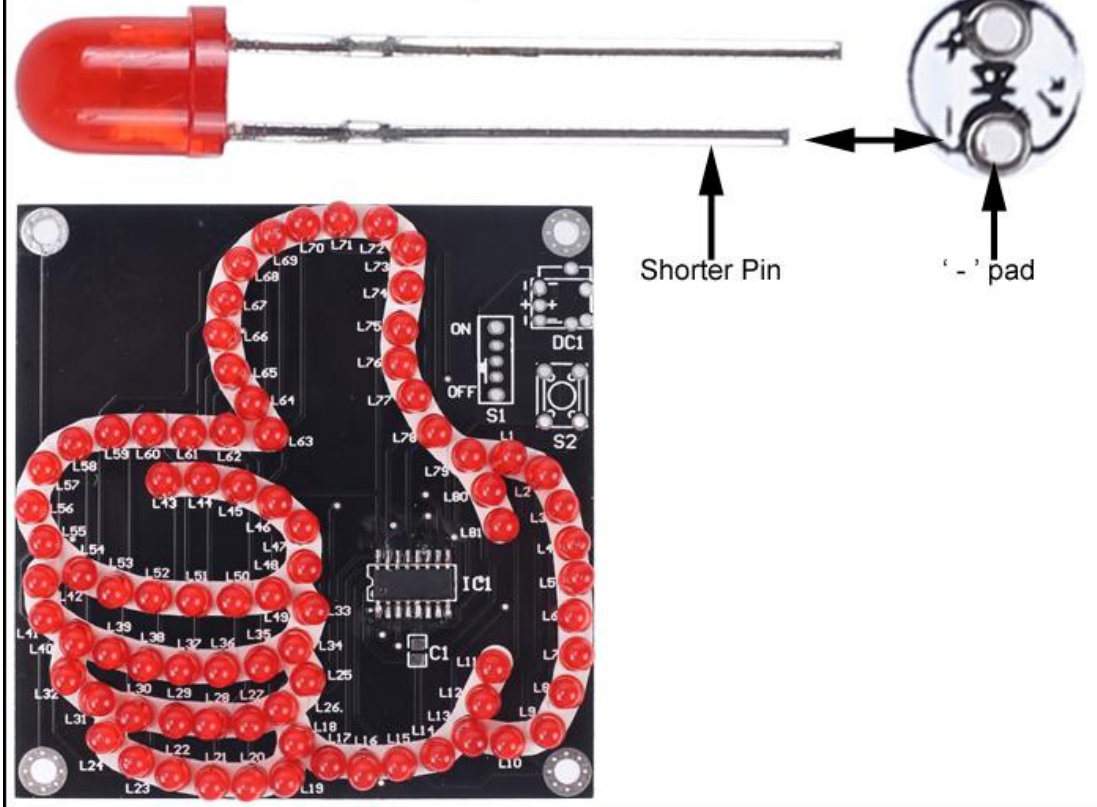

Step 6: Install 1pcs 6*6mm Black Button at S2.

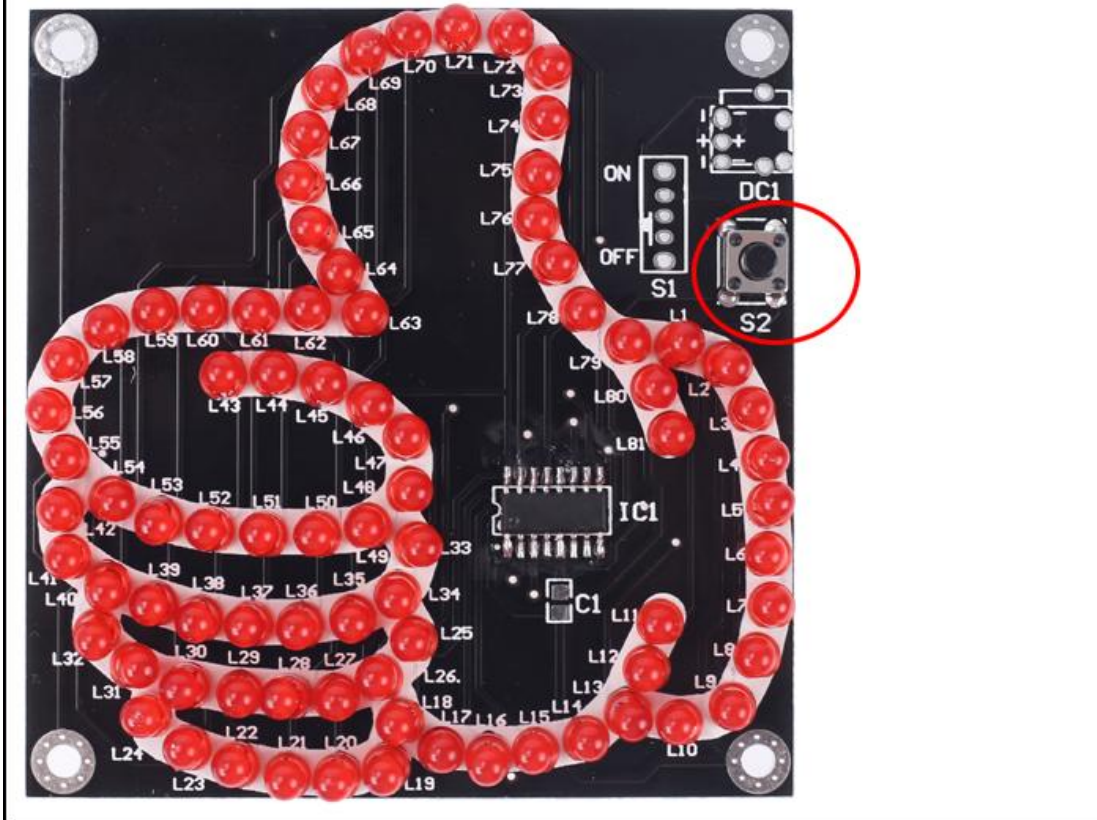

Step 7: Install 1pcs DC-003 Power Socket at DC1.



Step 8: Install 1pcs SS-12D07 Toggle Switch at S1.

