

FM Stereo Radio Module DIY Kit

1.Introduction:

The YFM-2 type radio circuit is very simple. The total number of components does not exceed 19pcs. Although the number of components is not large, it includes two types of components: SMD and DIP which are suitable for novices and friends who want to practice soldering of SMD components.

2.Feature:

- 1>.Built-in digital automatic gain control (AGC) circuit
- 2>.Support the global frequency band 76-108Mhz
- 3>.DIY manual soldering
- 4>.Simple and easy to operate
- 5>.Support radio memory function

3.Parameter:

- 1>.Item name: FM Stereo Radio Module DIY Kit
- 2>.Item Mode:YFM-2
- 3>.Work Voltage:DC 3V
- 4>.Work Current:19mA
- 5>.Work Frequency:76-108Mhz
- 6>.Output impedance:32ohm
- 7>.Work Temperature:-40°C~85°C
- 8>.Work Humidity:0%~95%RH
- 9>.Size(Installed):57*32*20mm

4.Component listing:

NO.	Component Name	PCB Marker	Parameter	QTY
1	RDA5807FP	U1	SOP-16	1
2	Metal Film Resistor	R1	30K ohm	1
3	Inductor	L1	0.1uH	1
4	Inductor	L2,L3	1uH	2
5	Ceramic Capacitor	C1	24pF	1
6	Ceramic Capacitor	C2	0.01pF(103)	1
7	Ceramic Capacitor	C3	0.022pF(223)	1
8	Electrolytic Capacitor	C4,C5	100uF 16V	2
9	Crystal Oscillator	Y1	32.768K	1

10	Black Switch	S1-S5	6*6*5mm	5
11	Audio Jack	J1	3.5mm	1
12	Cable tie		3*60mm	2
13	AA*2 Battery Box			1
14	PCB		56*30*1.6mm	1

Note:Users can complete the installation according to the PCB silk screen and component list.

5.Schematic:

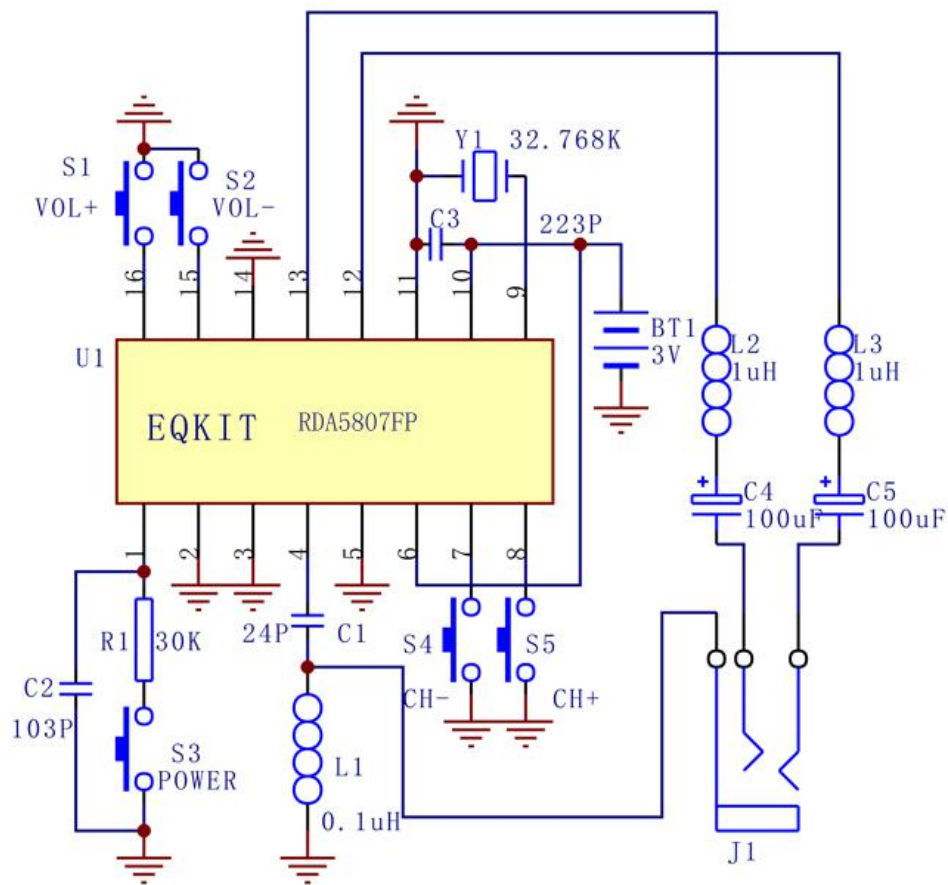

6.Application:

- 1>.Training welding skills
- 2>.Student school
- 3>.DIY production
- 4>.Project Design
- 5>.Electronic competition
- 6>.Graduation design
- 7>.Crafts collection
- 8>.Home decoration
- 9>.Souvenir collection

7. Installation Tips:

- 1>.User needs to prepare the soldering tool at first.
- 2>.Please be patient until the installation is complete.
- 3>.The package is DIY kit.It need finish install by user.
- 4>.The soldering iron can't touch the components for a long time(1.0 second), otherwise it will damage the components.
- 5>.Pay attention to the positive and negative of the components.
- 6>.Strictly prohibit short circuit.
- 7>.Install complex components preferentially.
- 8>.Make sure all components are in right direction and right place.
- 9>.Please wear anti-static gloves or anti-static wristbands when installing electronic components.
- 10>.It is strongly recommended to read the installation manual before starting installation!!!

8. Installation Steps(Please be patient install!!!):

- 1>.Step 1: Install 1pcs SOP-16 RDA5807FP at U1. There is a dot on one corner of the IC and there is a rectangle pad on PCB where the Pin1 of IC can place on. These two marks are corresponding to each other and are used to specify the installation direction of the IC. (Note: RDA5807FP can be installed after installed other components and recommend)
- 2>.Step 2: Install 1pcs 32.768KHz Crystal Oscillator at Y1.
- 3>.Step 3: Install 1pcs 30K ohm Resistor at R1.
- 4>.Step 4: Install 1pcs 0.1uH Inductor at L1.
- 5>.Step 5: Install 2pcs 1uH Inductor at L2,L3.
- 6>.Step 6: Install 1pcs 24pF Ceramic Capacitor at C1.
- 7>.Step 7: Install 1pcs 0.01pF(103) Ceramic Capacitor at C2.
- 8>.Step 8: Install 1pcs 0.022pF(223) Ceramic Capacitor at C3.
- 9>.Step 9: Install 5pcs 6*6*5mm Switch at S1-S5.
- 10>.Step 10: Install 1pcs 100uF 16V Electrolytic Capacitor at C4,C5. Please pay attention to the positive and negative poles. The shorter pin is the negative pole.
- 11>.Step 11: Install 1pcs 3.5mm Audio Jack at J1.
- 12>.Step 12: Connect battery box. Pay attention to positive and negative.
- 13>.Step 13: Use a cable tie to fasten the battery box.
- 14>.Step 14: Connect to power supply and enjoy the effect.

9. Install shown steps:

Step 1: Install 1pcs SOP-16 RDA5807FP at U1. There is a dot on one corner of the IC and there is a rectangle pad on PCB where the Pin1 of IC can place on. These two marks are corresponding to each other and are used to specify the installation direction of the IC. (Note: RDA5807FP can be installed after installed other components and recommend)

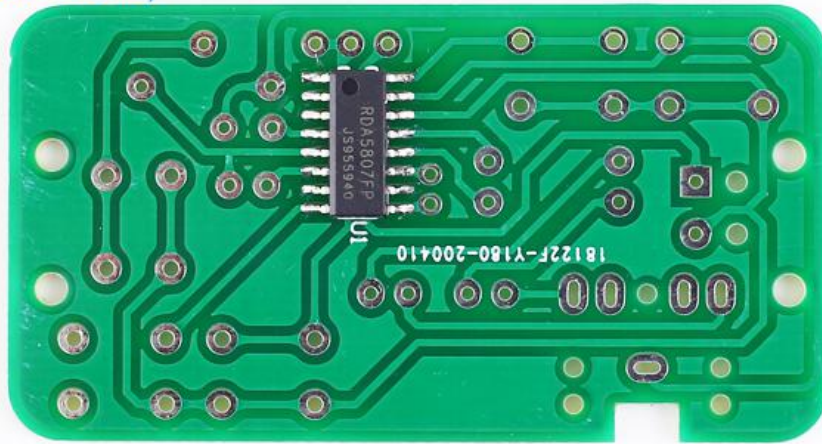
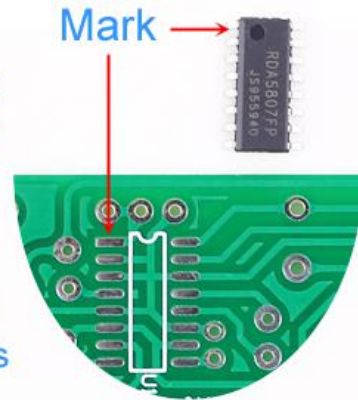

Step 2: Install 1pcs 32.768KHz Crystal Oscillator at Y1.

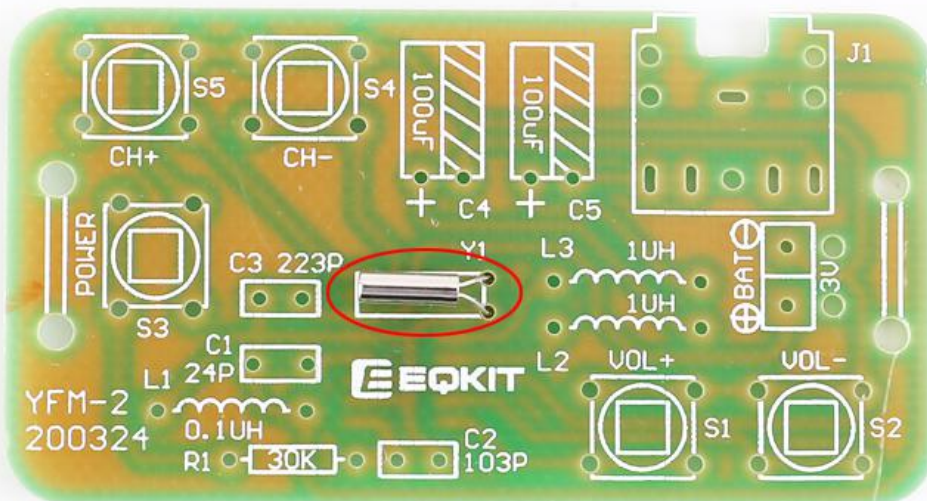

Step 3: Install 1pcs 30K ohm Resistor at R1.

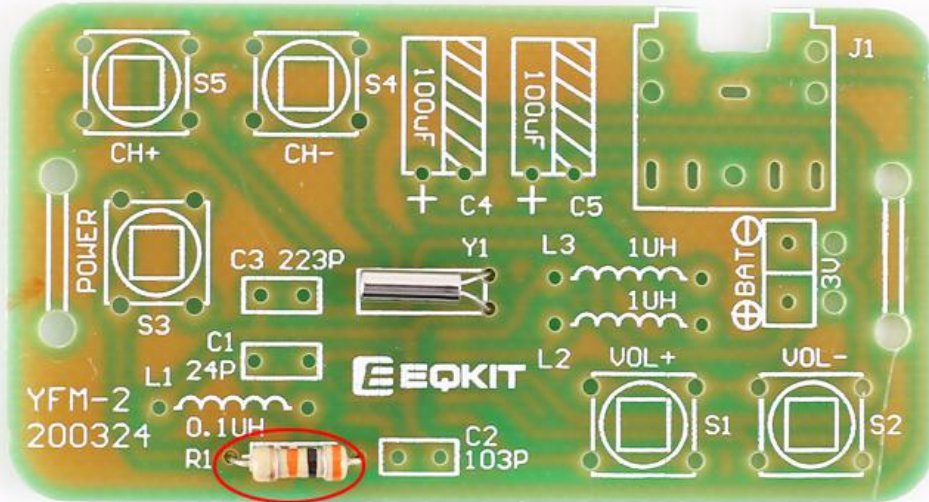

Step 4: Install 1pcs 0.1uH Inductor at L1.

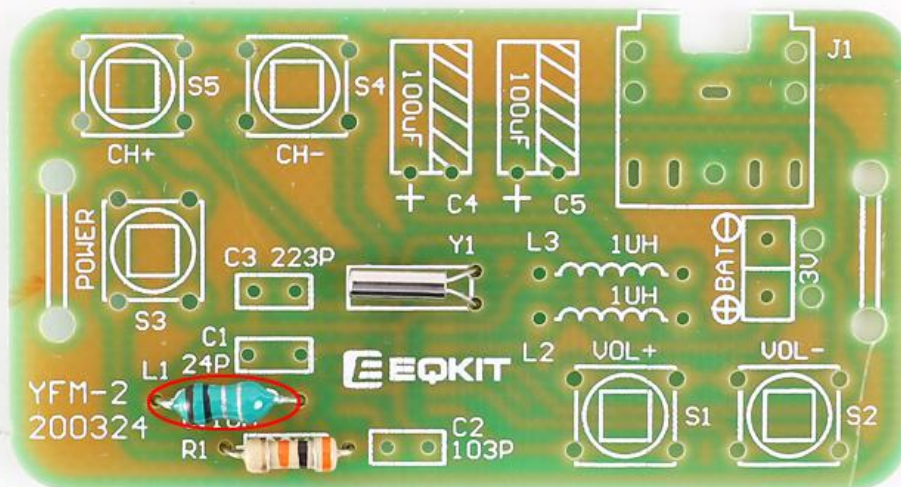

Step 5: Install 2pcs 1uH Inductor at L2,L3.

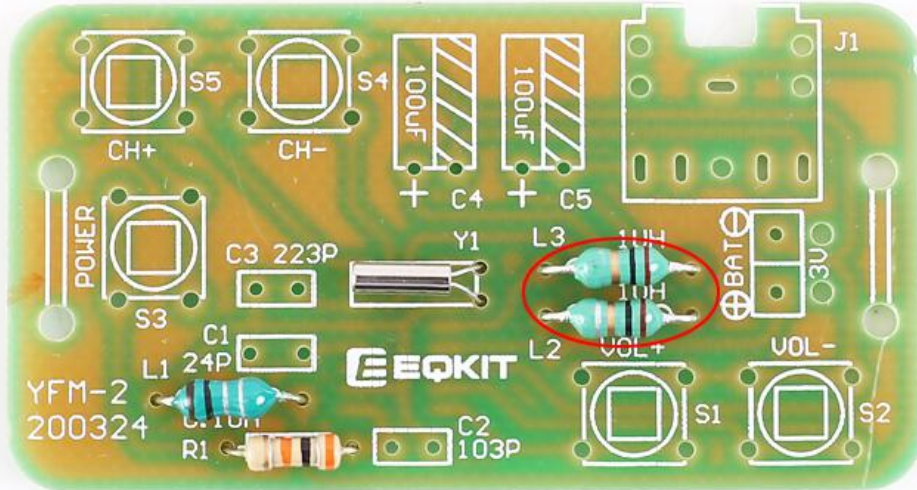

Step 6: Install 1pcs 24pF Ceramic Capacitor at C1.

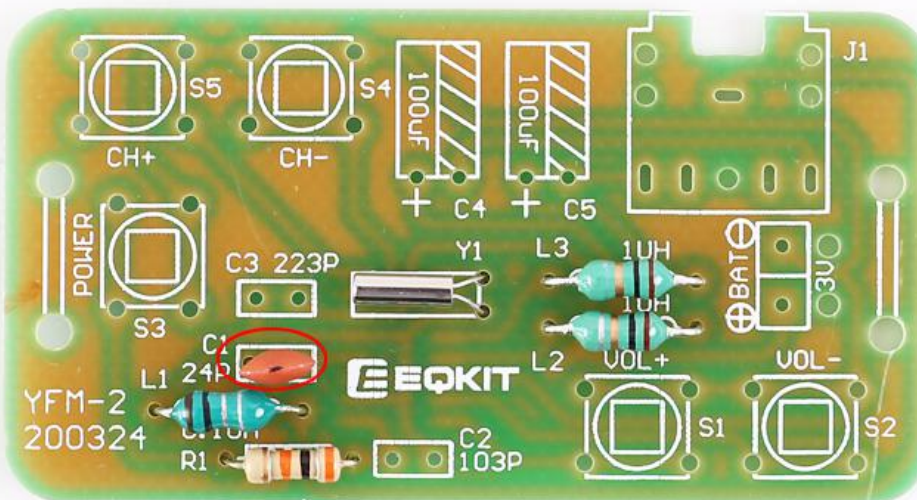

Step 7: Install 1pcs 0.01pF(103) Ceramic Capacitor at C2.

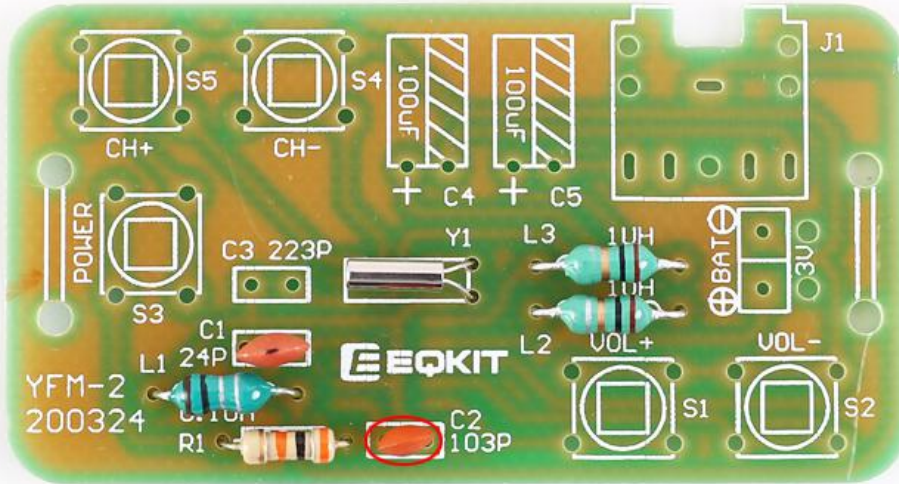

Step 8: Install 1pcs 0.022pF(223) Ceramic Capacitor at C3.

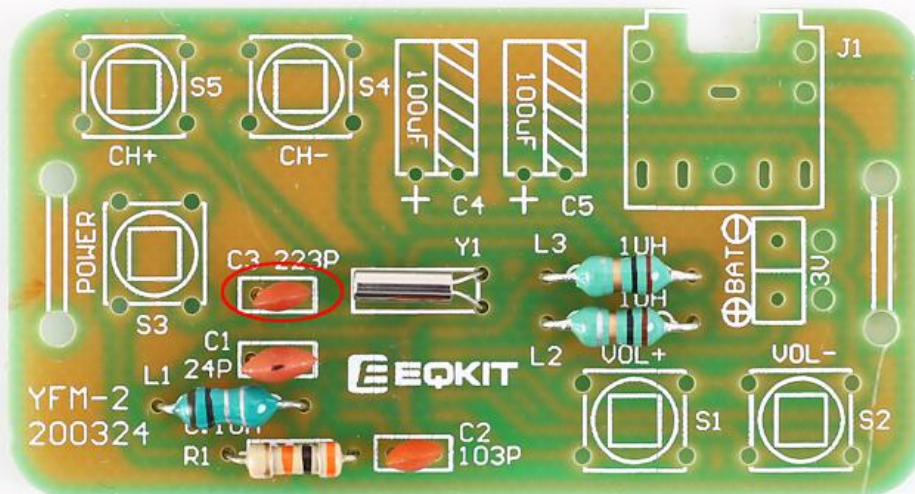

Step 9: Install 5pcs 6*6*5mm Switch at S1-S5.

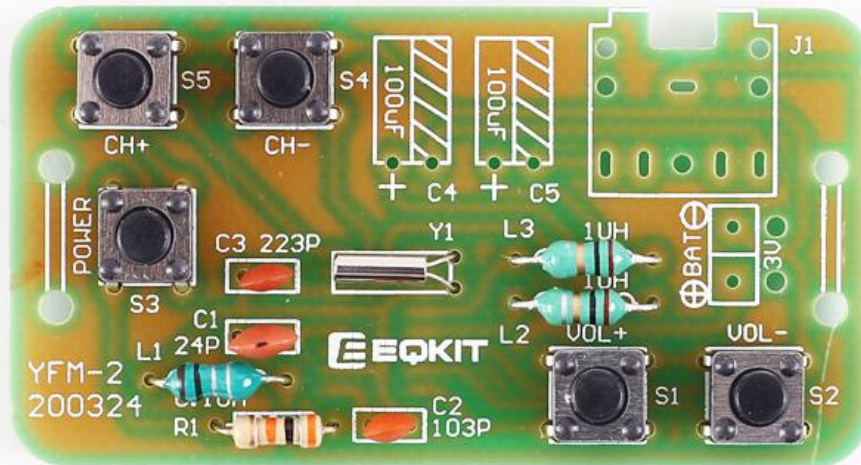

Step 10: Install 1pcs 100uF 16V Electrolytic Capacitor at C4,C5. Please pay attention to the positive and negative poles. The shorter pin is the negative pole.

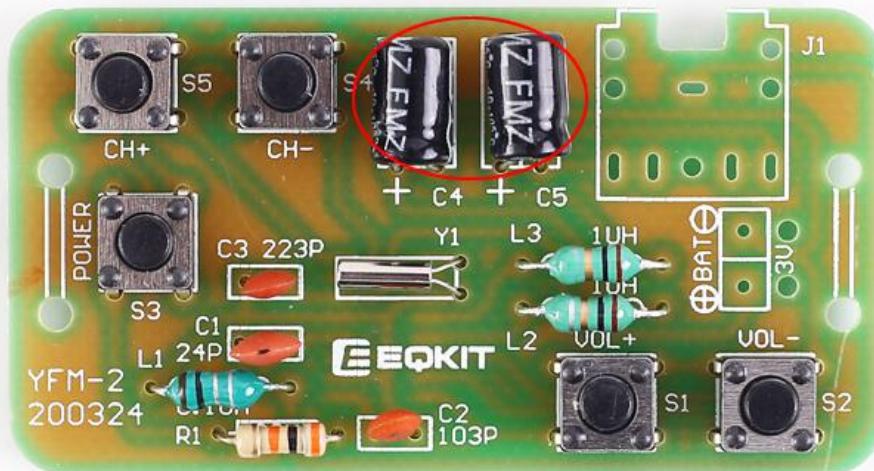

Step 11: Install 1pcs 3.5mm Audio Jack at J1.

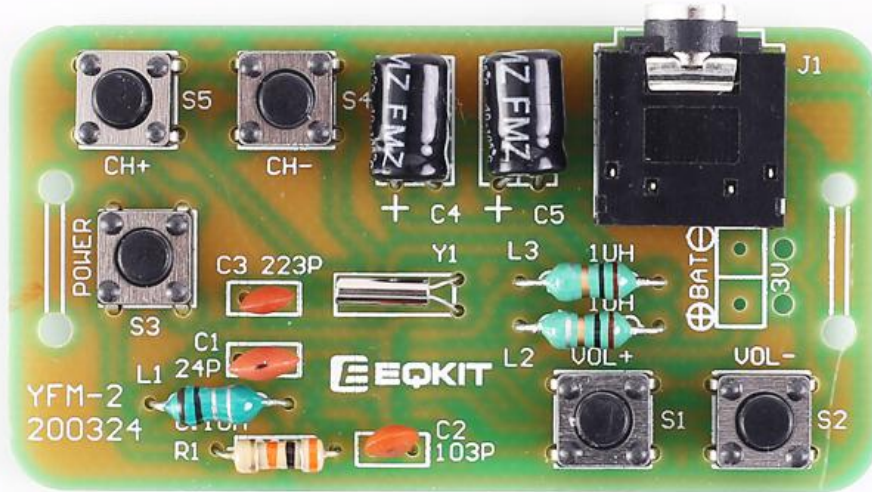

Step 12: Connect battery box.
Pay attention to positive and negative.



Step 13: Use a cable tie to fasten the battery box.
Step 14: Connect to power supply and enjoy the effect.

