

## LED Spectrum FM Bluetooth Audio Speaker DIY Kit

### 1.Introduction:

It is a LED Spectrum FM Bluetooth Audio Speaker DIY Kit with Infrared Remote Control. The kit features a 12-piece display of pink, blue, and green LEDs that move with the rhythm of the music. It can play music from FM radio, Bluetooth-enabled devices, AUX, U-disk, and TF cards, and the 3W 4ohm speakers produce clear and loud sound.

This DIY electronic product is an intriguing way for users to gain a better understanding of circuits and develop their soldering skills.

### 2.Feature:

1>.Multi-Audio Source Selectable: This device offers a variety of audio input options, including Bluetooth, FM, AUX, U-disk, and TF Card, enabling the playback of MP3 or lossless music files with a screen display indicating the current audio source. Users can control the music playback functions such as play/pause/next/prev/vol+/vol- using either the remote controller or on-board buttons.

2>.Bluetooth Player : With its built-in Bluetooth audio receiver and power amplifier, this device can directly drive 4ohm 3W speakers, producing clear and high-quality sound.

3>.LED Spectrum Display: The device also features 12 pink/blue/green LED spectrum indicators that flash in sync with the music, creating a dynamic and visually stunning lighting effect. The LED audio indicator flashes at both ends simultaneously, and the sensitivity is adjustable using the potentiometer.

4>.Dual Channel Stereo Speaker: The device can drive two 2.0 3W\*2 speakers, producing clear and powerful stereo sound.

5>.DIY Hand Soldering: This is a DIY kit that comes with various components, and users need to install each component by hand. This process not only enhances soldering skills but also fosters an interest in electronic technology. It's an excellent option for electronics hobbyists, beginners, as well as school and home education.

### 3.Parameter:

1>.Product Name:LED Spectrum FM Bluetooth Audio Speaker DIY Kit

2>.Work Voltage: DC 5V

3>.Work Current: >1.5A

4>.Speaker: 3W 4ohm

5>.Channel: Dual-Channel Stereo

6>.Audio source:Bluetooth/FM/AUX/U-disk/TF Card

7>.FM station: Automatic radio search

8>.Receiver Frequency:87.0MHz~108.0MHz

9>.Frequency accuracy:0.1MHz

10>.Control Type:Bluetooth/Remote Controller/On Board Button

11>.LED Color:Pink/Blue/Green

12>.Output type: Speaker

13>.Audio format:APE/FLAC/WAV/MP3/WMA

14>.Power interface: DC-005 Power Socket

15>.Work Temperature:-20℃~85℃

16>.Work Humidity:5%~85%RH

17>.Size(Installed):148\*81\*68mm

### 4.Use Methods:

1>.Switch Red/Black Switch to turn ON/OFF work power supply.

2>.MODE Button: Switch Audio Mode. Press the button to alternate between Bluetooth, FM, AUX, U-disk, and TF Card playback modes. Note: When using U-disk or TF Card, insert it first to play music.

3>.SCAN Button: Short press to play or pause music. Press and hold for 3 seconds to initiate automatic radio search in FM mode.

4>.VOL+ Button: Short press to switch next music. Hold it down for 3 seconds to increase the volume (V++).

5>.VOL- Button: Short press to switch previous music. Hold it down for 3 seconds to decrease the volume (V--).

6>.Potentiometer: It is used to adjust volume by screwdriver.

## 5.Component Listing:

| NO. | Component Name               | PCB Marker         | Parameter | QTY |
|-----|------------------------------|--------------------|-----------|-----|
| 1   | Metal Film Resistor          | R7,R8,R11,R12      | 100ohm    | 4   |
| 2   | Metal Film Resistor          | R15,R16            | 200ohm    | 2   |
| 3   | Metal Film Resistor          | R5,R13,R14,R17,R18 | 510ohm    | 5   |
| 4   | Metal Film Resistor          | R9,R10             | 1Kohm     | 2   |
| 5   | Metal Film Resistor          | R28                | 2Kohm     | 1   |
| 6   | Metal Film Resistor          | R2,R4,R6           | 5.1Kohm   | 3   |
| 7   | Metal Film Resistor          | R1,R25             | 10Kohm    | 2   |
| 8   | Metal Film Resistor          | R3                 | 1Mohm     | 1   |
| 9   | LM358 IC                     | U1,U2,U3,U4        | DIP-8     | 4   |
| 10  | IC Socket                    | U1,U2,U3,U4        | DIP-8     | 4   |
| 11  | 5mm Pink LED                 | D2,D3,D4,D5        | 2Pin      | 4   |
| 12  | 5mm Blue LED                 | D6,D7,D8,D9        | 2Pin      | 4   |
| 13  | 5mm Green LED                | D10,D11,D12,D13    | 2Pin      | 4   |
| 14  | 1N4148 Diode                 | D1,D22             | DO-35     | 2   |
| 15  | Electrolytic Capacitor       | C4                 | 4.7uF     | 1   |
| 16  | Electrolytic Capacitor       | C2                 | 100uF     | 1   |
| 17  | Monolithic Capacitor         | C1,C3              | 0.1uF 104 | 2   |
| 18  | Potentiometer                | RP                 | 1Mohm     | 1   |
| 19  | MIC Microphone               | MIC                | 9.7mm     | 1   |
| 20  | PH2.0-2P White Socket        | CZ                 | 2.0mm     | 1   |
| 21  | PH2.0-2P Wire                |                    | 15cm      | 4   |
| 22  | Bluetooth Receiver           |                    |           | 1   |
| 23  | Infrared Remote Controller   |                    |           | 1   |
| 24  | 4ohm 3W Speaker              |                    |           | 1   |
| 25  | DC-005 Power Socket          |                    |           | 1   |
| 26  | FM Antenna Wire              |                    | 15cm      | 1   |
| 27  | Red/Black Switch             |                    |           | 1   |
| 28  | USB-DC005 Power Wire         |                    |           | 1   |
| 29  | Transparent Acrylic Board    |                    |           | 6   |
| 30  | M3*5+6mm Copper Pillar Screw |                    |           | 2   |
| 31  | M3*6mm Screw                 |                    |           | 10  |
| 32  | M3*5mm Screw                 |                    |           | 2   |
| 33  | M2*10mm Screw                |                    |           | 12  |
| 34  | M3 Nut                       |                    |           | 12  |
| 35  | M2 Nut                       |                    |           | 12  |
| 36  | PCB                          |                    | 100*30mm  | 1   |

NOTE:Users can complete the installation according to the PCB silk screen and component list.

## 6.Schematic Diagram for LED Spectrum Indicator:

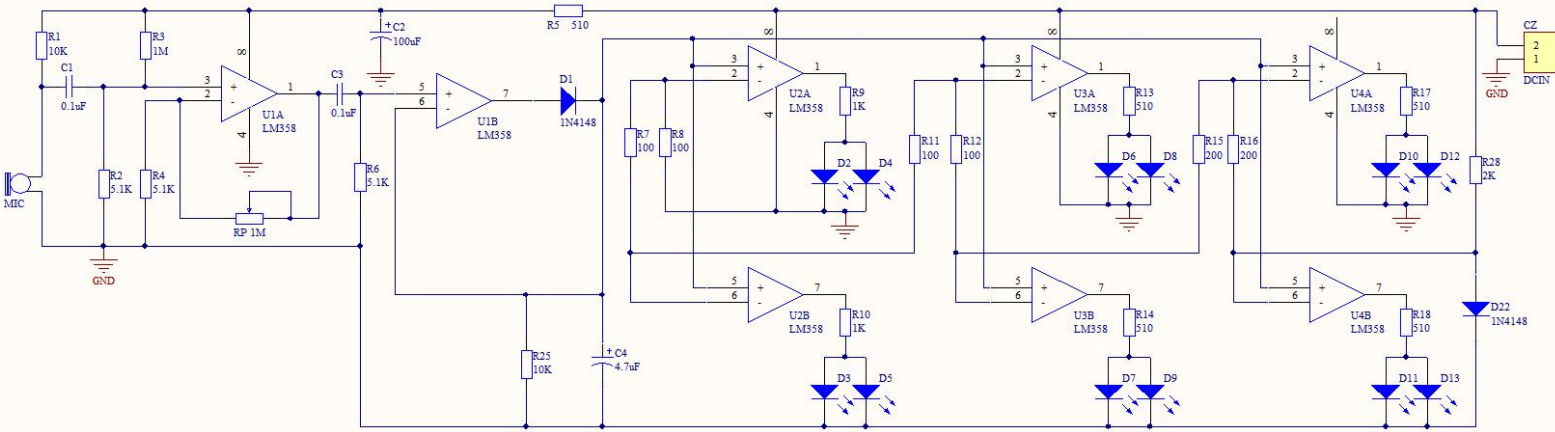

### 7.Application:

- 1>.Training welding skills
- 2>.Student school
- 3>.DIY production
- 4>.Project Design
- 5>.Electronic competition
- 6>.Gift giving
- 7>.Crafts collection
- 8>.Home decoration
- 9>.Souvenir collection
- 10>.Graduation design
- 11>.Holiday gift

### 8.Installation Tips:

- 1>.User needs to prepare the welding tool at first.
  - 1.1>.Soldering iron (<50 Watt)
  - 1.2>.Rosin core ("radio") solder
  - 1.3>.Wire cutters
  - 1.4>.Wire strippers
  - 1.5>.Philips screwdriver
- 2>.Kindly wait patiently until the installation process has been completed.
- 3>.The package is a DIY kit that requires the user to complete the installation.
- 4>.Prolonged contact of the soldering iron with the components may result in damage to them.

Therefore, exercise caution.

- 5>.Take note of the polarity of the components to ensure proper installation.
- 6>.Short-circuiting is strictly prohibited.
- 7>.The LED must be installed in accordance with the specified guidelines; otherwise, some LEDs may not light up.
- 8>.It is recommended to install complex components first.
- 9>.Ensure that all components are correctly oriented and placed in the right location.
- 10>.Verify that all LEDs are functional and light up.
- 11>.We strongly advise that you peruse the installation manual prior to commencing installation.
- 12>.When installing electronic components, it is advisable to wear anti-static gloves or an anti-static wristband to prevent damage.

### 9.Installation Steps(Please be patient install!!!):

- 1>.Step 1: Install 5pcs 510ohm Metal Film Resistor at R5,R13,R14,R17,R18. Its color is green/brown/black/black/brown.
- 2>.Step 2: Install 4pcs 100ohm Metal Film Resistor at R7,R8,R11,R12. Its color is brown/black/black/black/brown.
- 3>.Step 3: Install 3pcs 5.1Kohm Metal Film Resistor at R2,R4,R6. Its color is green/brown/black/brown/brown.
- 4>.Step 4: Install 2pcs 1Kohm Metal Film Resistor at R9,R10. Its color is

brown/black/black/brown/brown. Note: Screen printing 510ohm ignored.

5>.Step 5: Install 2pcs 10Kohm Metal Film Resistor at R1,R25. Its color is brown/black/black/red/brown.

6>.Step 6: Install 2pcs 200ohm Metal Film Resistor at R15,R16. Its color is red/black/black/black/brown.

7>.Step 7: Install 1pcs 2Kohm Metal Film Resistor at R28. Its color is red/black/black/brown/brown.

8>.Step 8: Install 1pcs 1Mohm Metal Film Resistor at R3. Its color is brown/black/black/yellow/brown.

9>.Step 9: Install 2pcs DO-35 1N4148 Diode at D1,D22. Please ensure you pay attention to the direction of installation. The 1N4148 has a black mark and the PCB has a white mark that are used to verify the correct installation direction.

10>.Step 10: Install 4pcs DIP-8 IC Socket at U1,U2,U3,U4.An IC Socket has a mark, also known as a notch, on one end, and a curved silk screen printing mark on the PCB where the IC Socket is meant to be placed. These two marks are aligned with each other and serve to indicate the specific direction in which the IC Socket should be installed.

11>.Step 11: Determine the positive (anode) and negative (cathode) leads of the LED. It is crucial to install the leads of the LED correctly to ensure that the LED functions properly. There are several methods to identify the leads:

11.1> One way to differentiate between the leads is by their length. The positive (anode) lead is longer, while the negative (cathode) lead is shorter.

11.2> To identify the negative (cathode) lead, inspect the plastic case of the LED. The negative (cathode) lead is thicker or bigger inside the plastic case compared to the anode lead.

11.3> Another way to identify the negative (cathode) lead is to observe the edge of the plastic case. The negative (cathode) lead should be the pin closest to the flat on the plastic case.

11.4> One can also use a 3V battery or multimeter to test the leads. The pin connected to the positive of the 3V power supply is the positive (anode) lead if the LED lights up after being powered. However, it is crucial to note that the LED should not be directly powered by 3V for a period shorter than 0.5 seconds.

11.5> Additionally, the positive (anode) lead is where the white mark "+" is pointing on the PCB.

12>.Step 12: The pins of an LED should be bent to a 90-degree angle, taking care to note the bending point and direction. It is important to pay attention to the direction in which the pins are bent to ensure proper functionality.

13>.Step 13: Install 4pcs 5mm Pink LED at D2,D3,D4,D5.

14>.Step 14: Install 4pcs 5mm Blue LED at D6,D7,D8,D9.

15>.Step 15: Install 4pcs 5mm Green LED at D10,D11,D12,D13.

16>.Step 16: Install 1pcs 4.7uF Electrolytic Capacitor at C4. The PCB silk screen printing features a white marking indicating where the negative (cathode) lead can be inserted. It's important to note that the shorter lead is the negative (cathode) pole, and the capacitor must be placed horizontally.

17>.Step 17: Install 1pcs 100uF Electrolytic Capacitor at C2. The PCB silk screen printing features a white marking indicating where the negative (cathode) lead can be inserted. It's important to note that the shorter lead is the negative (cathode) pole, and the capacitor must be placed horizontally.

18>.Step 18: Install 2pcs 0.1uF 104 Monolithic Capacitor at C1,C3.

19>.Step 19: Install 1pcs 9.7mm MIC Microphone at MIC.To differentiate between the positive and negative poles, pay attention to the marked pin, which is the negative pole.

20>.Step 20: Install 1pcs 1Mohm Potentiometer at RP. Note: It needs to be installed on the other side of the PCB.

21>.Step 21: Install 4pcs DIP-8 LM358 Amplifier at U1,U2,U3,U4.Look for a gap mark on one end of the IC and a corresponding gap mark on the DIP-8 IC Socket. These marks are used to indicate the installation direction of the IC.

22>.Step 22: Install 1pcs PH2.0-2P Wire at CZ on the PCB back. Note: Red wire connect to ' + ' pad and black wire connect to ' - ' pad. Otherwise, the LED spectrum board will be damaged.

23>.Step 23: Connect PH2.0-2P Wire to 4ohm 3W Speaker. Red wire connect to ' + ' pad.

24>.Step 24: Tear off the protective film on the surface of the acrylic boards.

25>.Step 25: Fix 1pcs DC-005 Power Socket by its nut on acrylic board.

26>.Step 26: Fix 1pcs Red/Black Switch on acrylic panel. Pay attention to the buckle on the switch, which can be fixed by itself.Pay attention to the installation direction.

27>.Step 27: Cut about 3cm red wire to connect DC-005 Power Socket and Red/Black Switch.Pay

attention to their pin selection and can not choose to connect other pins.

28>.Step 28: Connect 1pcs 10cm PH2.0-2P Wire to DC-005 and Red/Black Switch. The red wire connect to Switch and the black wire connect to DC-005 Power Socket. Refer to the wiring location shown if the wire is in another color.

29>.Step 29: Crimp about 3cm Wire a FM Antenna and install it on Bluetooth Receiver as shown pad.

30>.Step 30: Fix Bluetooth Receiver on acrylic board by 2pcs M3\*6mm Screw and 2pcs M3 Nut.

31>.Step 31: Cut PH2.0-2P Plug from LED board and connect red/black wire to Bluetooth Receiver where has marked '5V' and 'GND'. Note: red wire connect to '5V' pad from 'IN+' pad.

32>.Step 32: Fix 2pcs M3\*5+6mm Copper Pillar Screw on LED board by 2pcs M3 Nut.

33>.Step 33: Fix LED spectrum board on another acrylic board by 2pcs M3\*5mm Screw.

34>.Step 34: Fix 4ohm 3W Speaker on acrylic board by 4pcs M3\*6mm Screw and 4pcs M3 Nut. Pay attention to the installation direction of screws.

35>.Step 35: Fix 1pcs 4ohm 3W Speaker on LED acrylic by 2pcs M2\*10mm Screw and 2pcs M2 Nut.

36>.Step 36: Fix another 4ohm 3W Speaker on LED acrylic board by 2pcs M2\*10mm Screw and 2pcs M2 Nut.

37>.Step 37: Fix Bluetooth Receiver on LED acrylic board by 2pcs M2\*10mm Screw and 2pcs M2 Nut. Pay attention to align the mounting holes of LED and acrylic.

38>.Step 38: Connect two speaker wire plug to white socket at Bluetooth Receiver.

39>.Step 39: Install another acrylic board with switch by 2pcs M2\*10mm Screw and 2pcs M2 Nut, But don't fix it too tightly at this time.

40>.Step 40: Connect PH2.0-2P plug from Red/Black Switch to red socket on Bluetooth Receiver.

41>.Step 41: Fix TOP acrylic board by 4pcs M2\*10mm Screw and 4pcs M2 Nut. And fix Screw in Step-39.

## 10.Install shown steps:

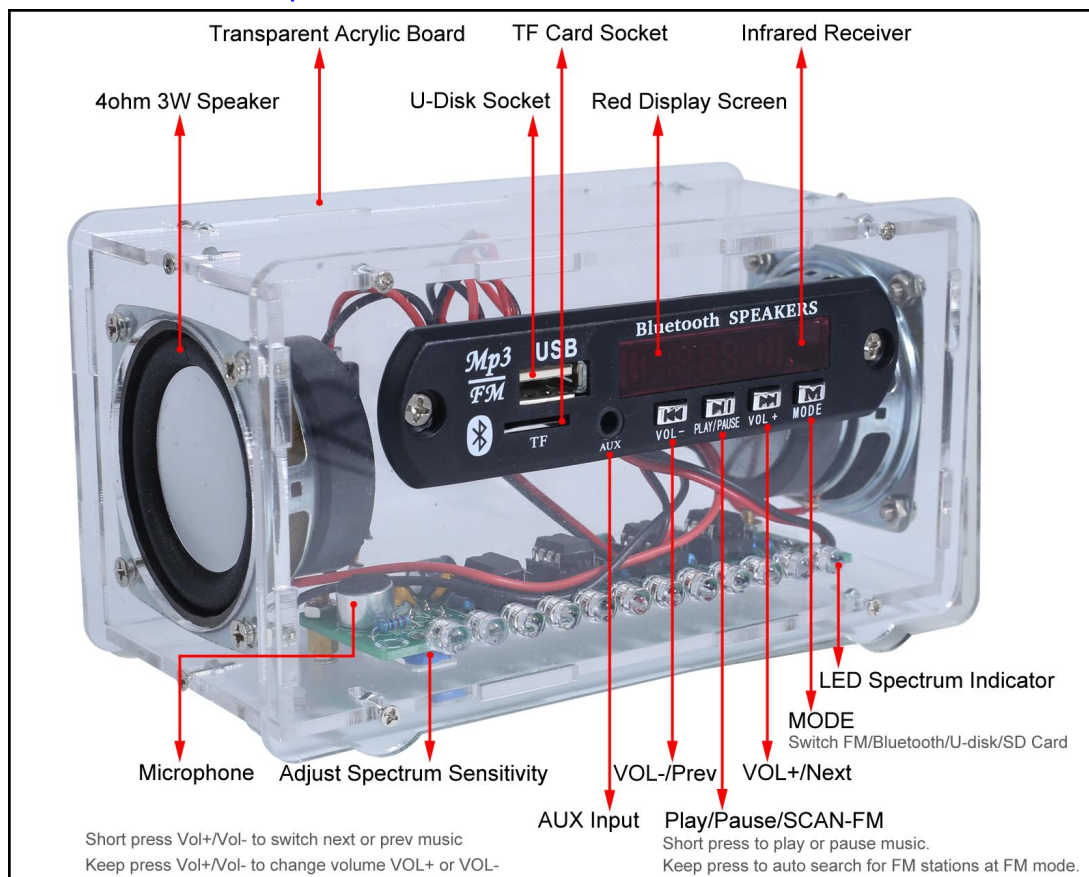



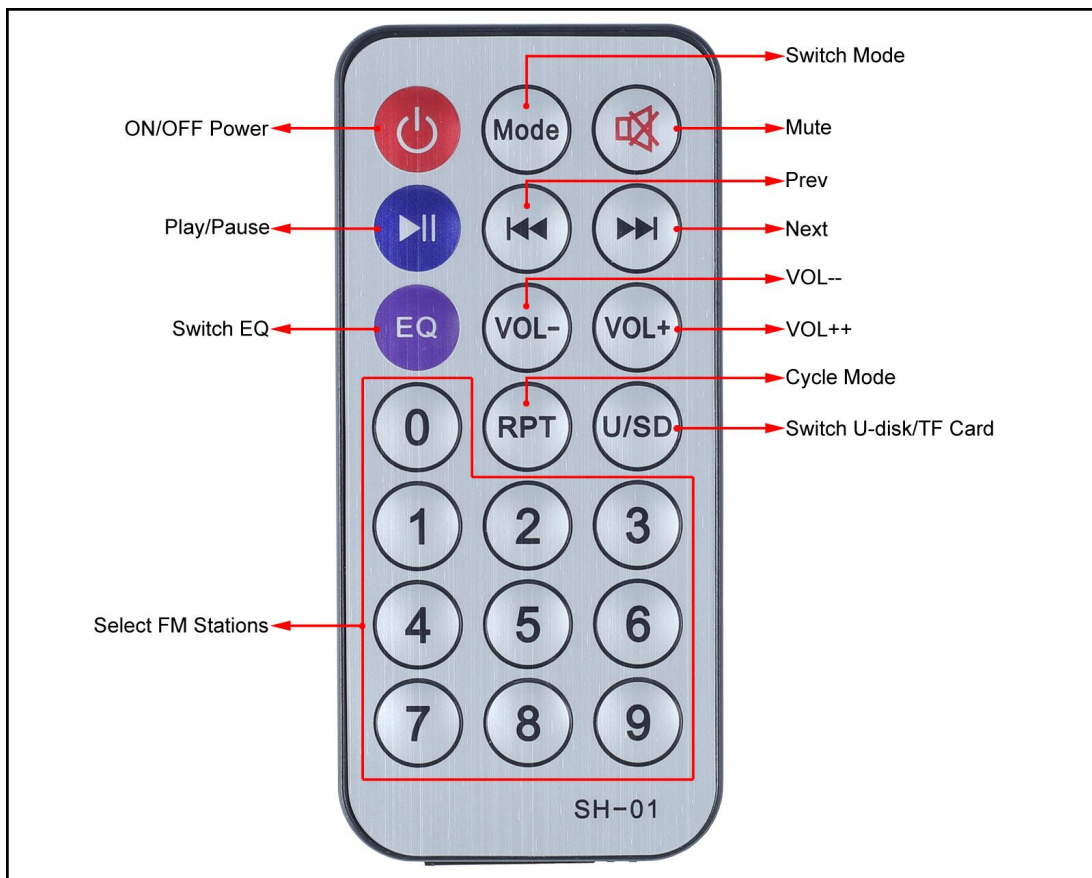
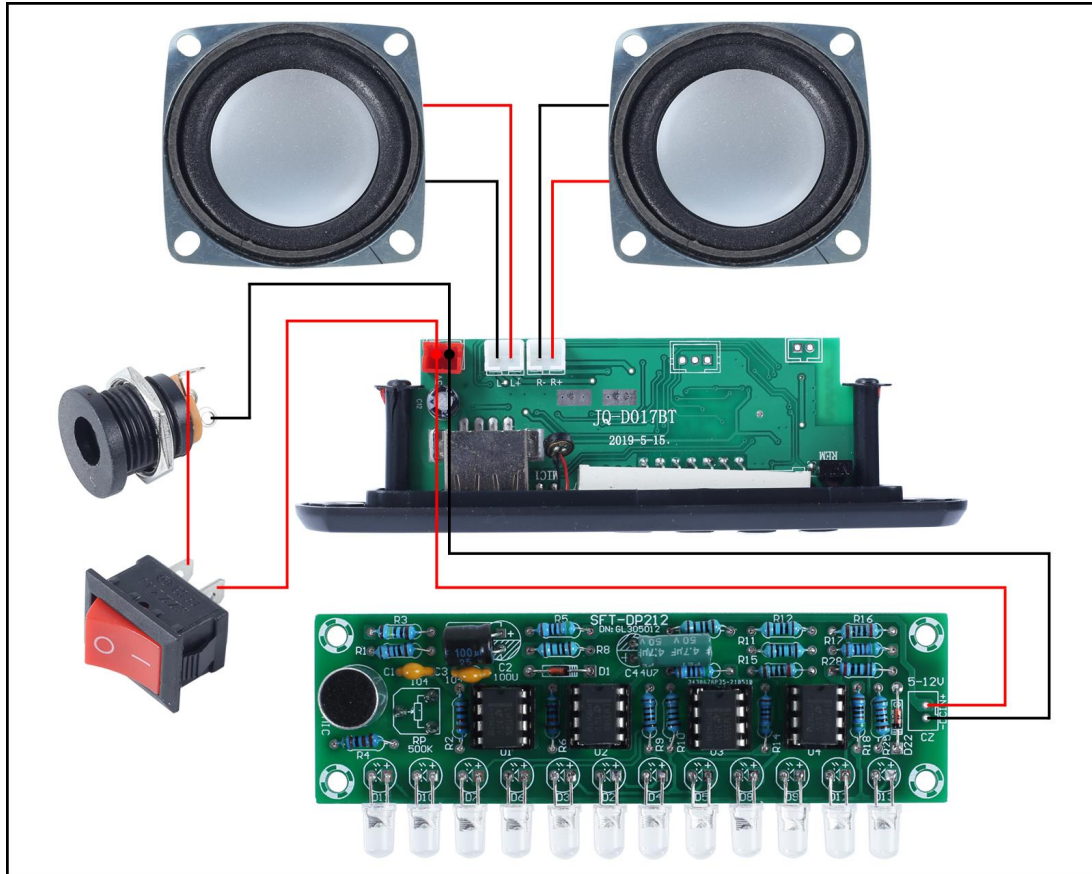



Step 1: Install 5pcs 510ohm Metal Film Resistor at R5,R13,R14,R17,R18.

Its color is green/brown/black/black/brown.

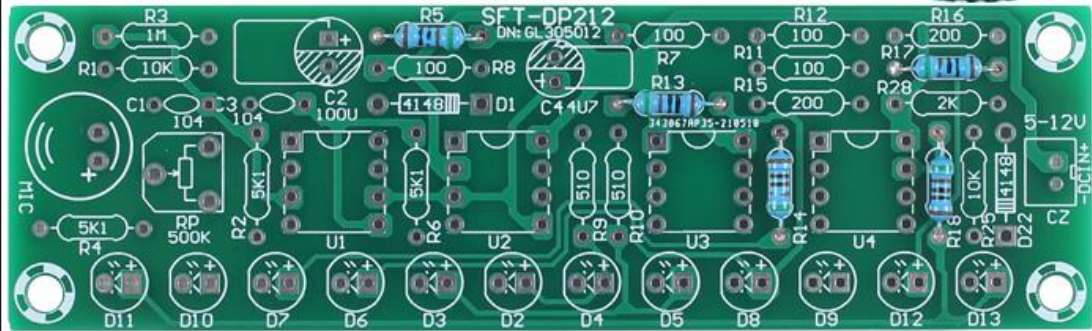

Step 2: Install 4pcs 100ohm Metal Film Resistor at R7,R8,R11,R12.

Its color is brown/black/black/black/brown.

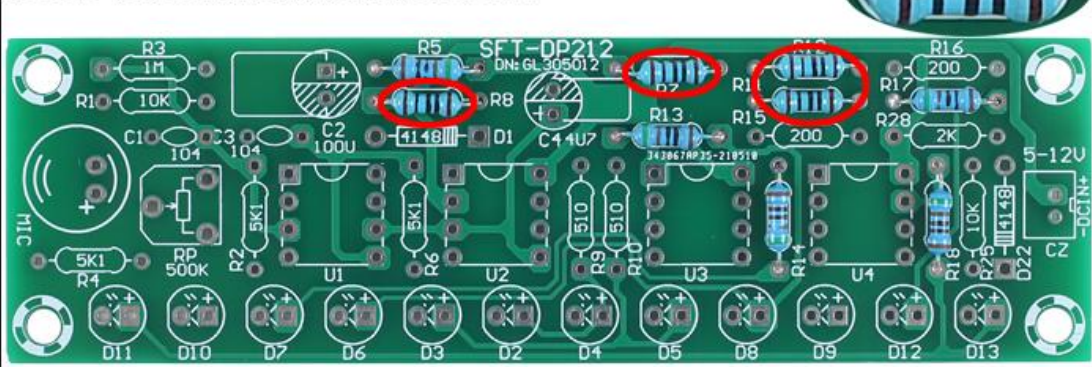

Step 3: Install 3pcs 5.1Kohm Metal Film Resistor at R2,R4,R6.

Its color is green/brown/black/brown/brown.

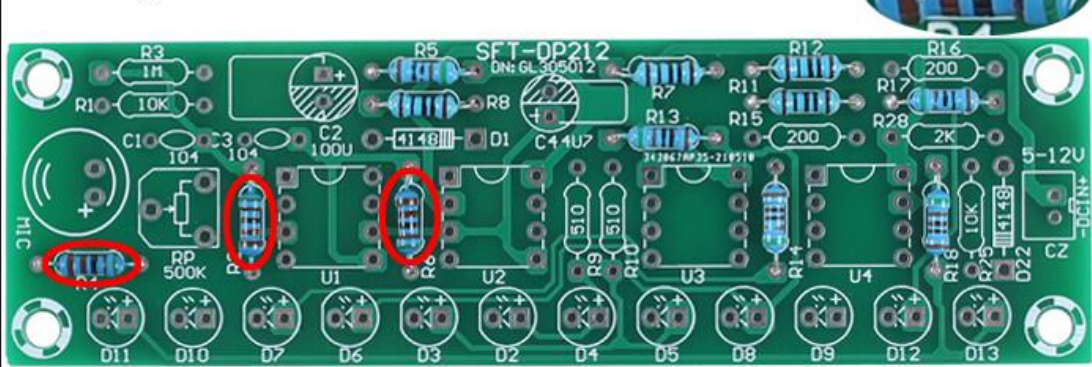

Step 4: Install 2pcs 1Kohm Metal Film Resistor at R9,R10.

Its color is brown/black/black/brown/brown.

Note: Screen printing 510ohm ignored.

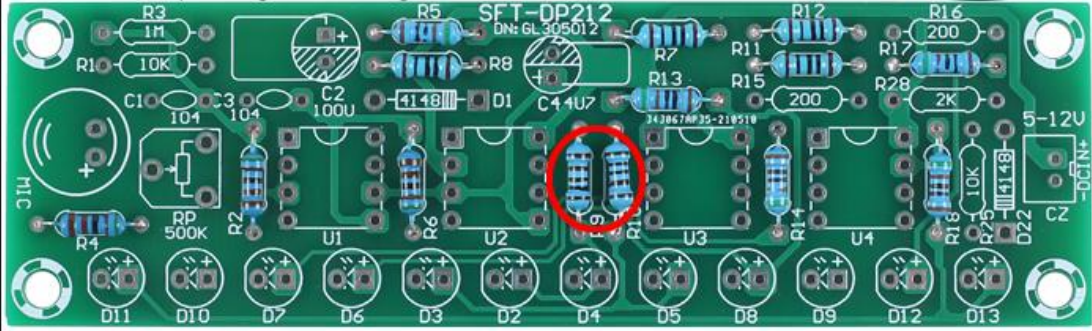



Step 5: Install 2pcs 10Kohm Metal Film Resistor at R1,R25.  
Its color is brown/black/black/red/brown.

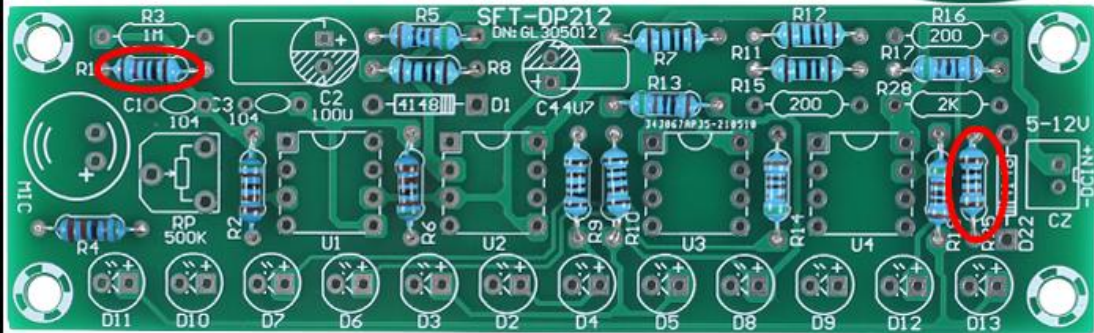

Step 6: Install 2pcs 200ohm Metal Film Resistor at R15,R16.  
Its color is red/black/black/black/brown.

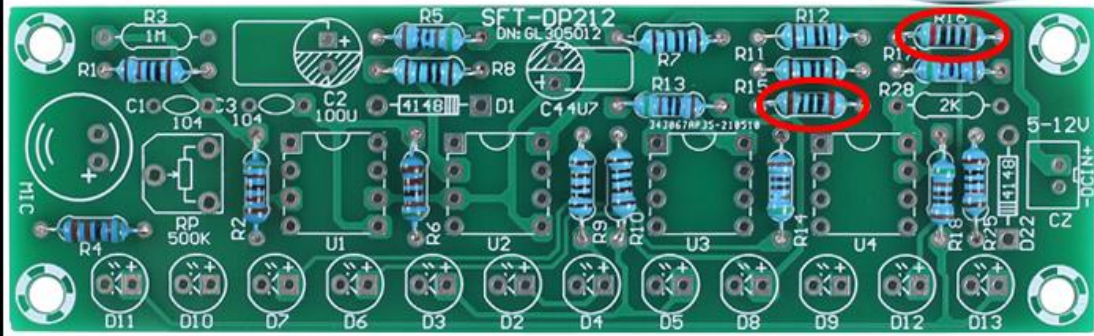

Step 7: Install 1pcs 2Kohm Metal Film Resistor at R28.  
Its color is red/black/black/brown/brown.

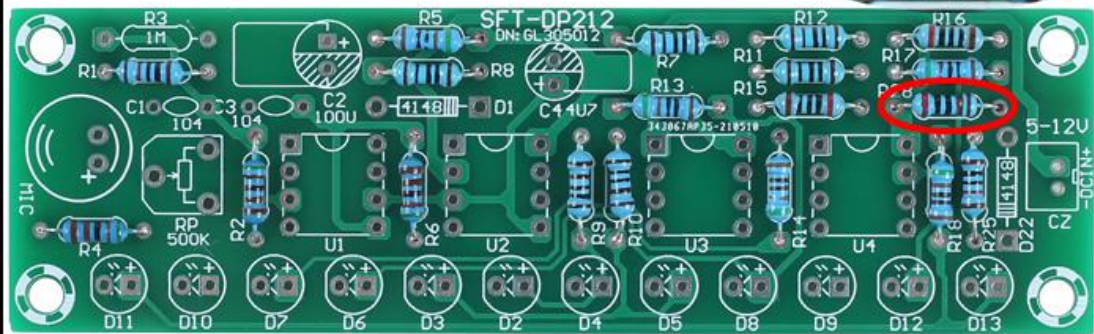

Step 8: Install 1pcs 1Mohm Metal Film Resistor at R3.  
Its color is brown/black/black/yellow/brown.

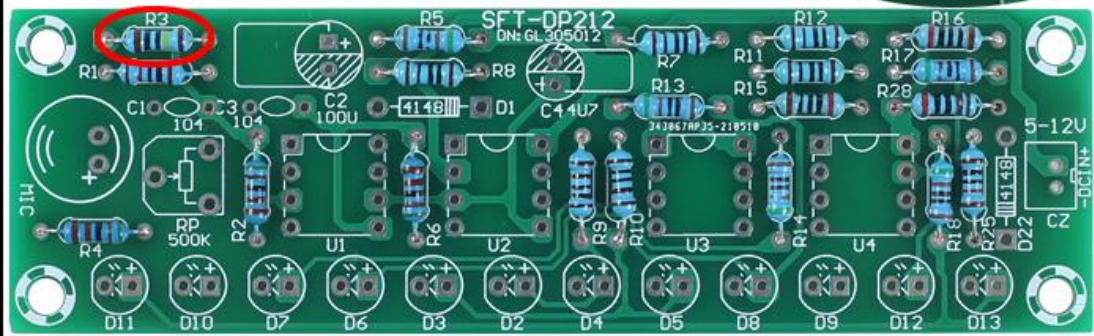



Step 9: Install 2pcs DO-35 1N4148 Diode at D1,D22. Please ensure you pay attention to the direction of installation. The 1N4148 has a black mark and the PCB has a white mark that are used to verify the correct installation direction

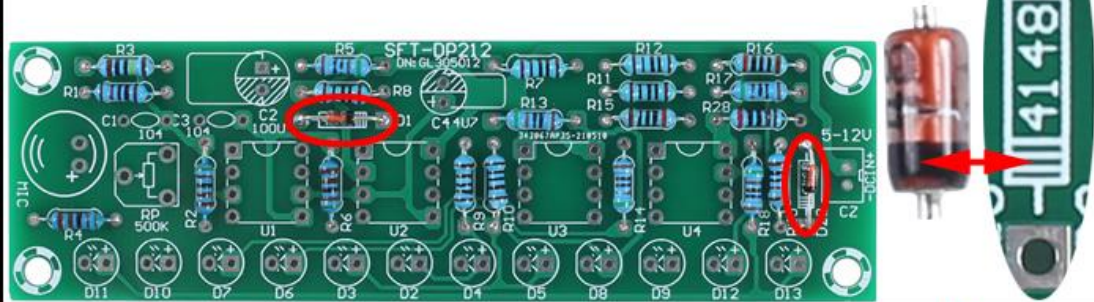

Step 10: Install 4pcs DIP-8 IC Socket at U1,U2,U3,U4. An IC Socket has a mark, also known as a notch, on one end, and a curved silk screen printing mark on the PCB where IC Socket is meant to be placed. These two marks are aligned with each other and serve to indicate specific direction in which IC Socket should be installed.

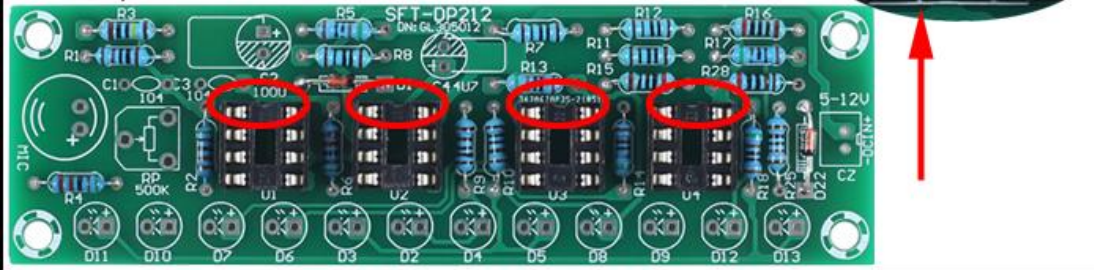

Step 11: Determine the positive (anode) and negative (cathode) leads of the LED. It is crucial to install the leads of the LED correctly to ensure that the LED functions properly. There are several methods to identify the leads:

- 11.1> One way to differentiate between the leads is by their length. The positive (anode) lead is longer, while the negative (cathode) lead is shorter.
- 11.2> To identify the negative (cathode) lead, inspect the plastic case of the LED. The negative (cathode) lead is thicker or bigger inside the plastic case compared to the anode lead.
- 11.3> Another way to identify the negative (cathode) lead is to observe the edge of plastic case. The negative (cathode) lead should be the pin closest to the flat on case.
- 11.4> One can also use a 3V battery or multimeter to test the leads. The pin connected to the positive of the 3V power supply is the positive (anode) lead if the LED lights up after being powered. However, it is crucial to note that the LED should not be directly powered by 3V for a period shorter than 0.5 seconds.
- 11.5> Additionally, the positive (anode) lead is where the white mark "+" is pointing on the PCB.

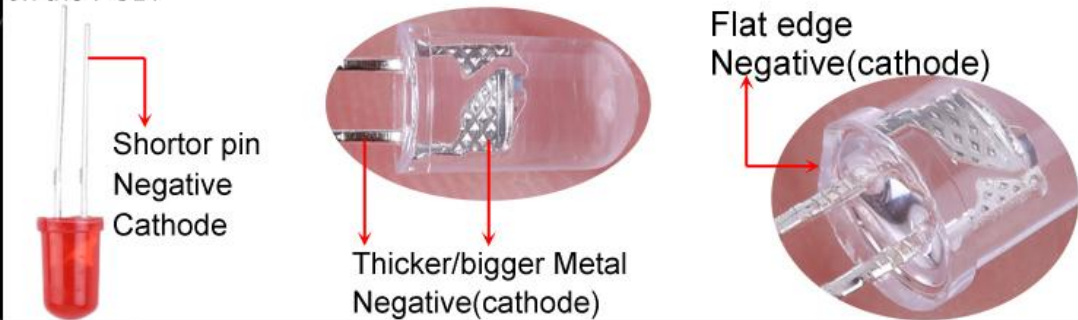



Step 12: The pins of an LED should be bent to a 90-degree angle, taking care to note the bending point and direction. It is important to pay attention to the direction in which the pins are bent to ensure proper functionality

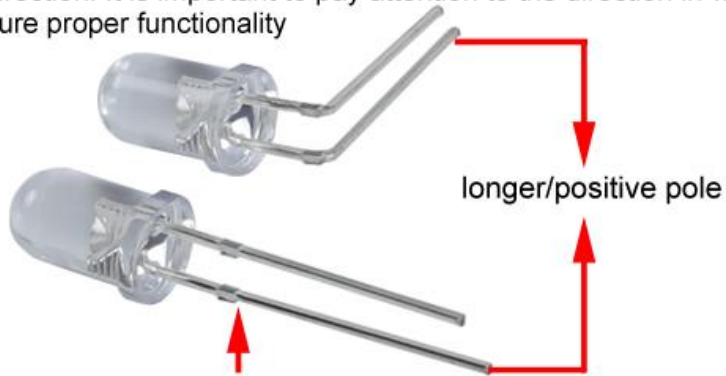

Step 13: Install 4pcs 5mm Pink LED at D2,D3,D4,D5.

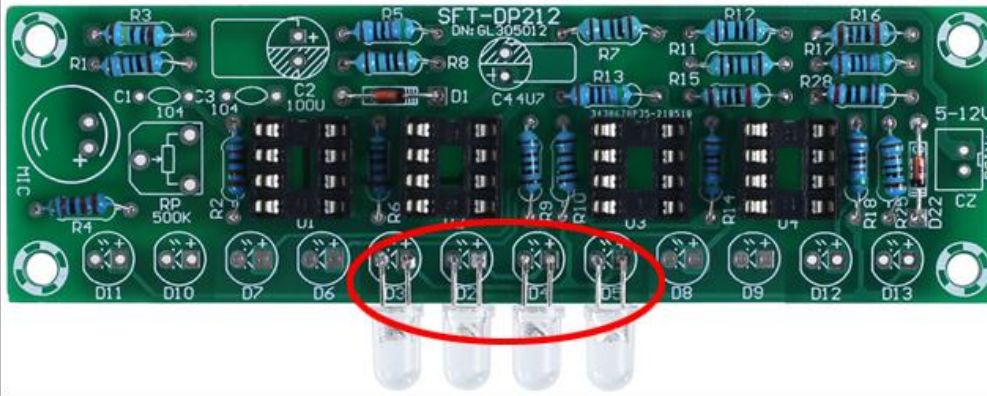

Step 14: Install 4pcs 5mm Blue LED at D6,D7,D8,D9.

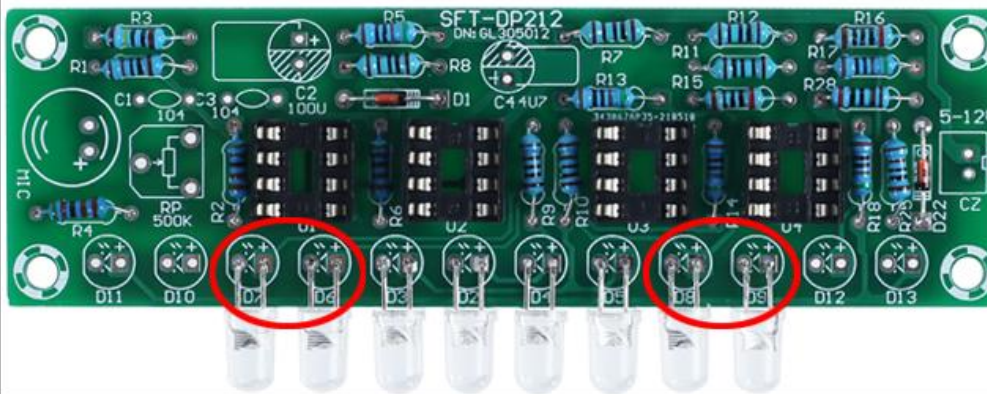

Step 15: Install 4pcs 5mm Green LED at D10,D11,D12,D13.





Step 16: Install 1pcs 4.7uF Electrolytic Capacitor at C4. The PCB silk screen printing features a white marking indicating where the negative (cathode) lead can be inserted. It's important to note that the shorter lead is the negative (cathode) pole, and the capacitor must be placed horizontally

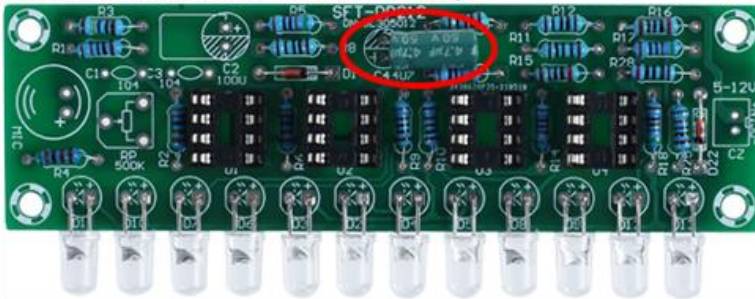

Step 17: Install 1pcs 100uF Electrolytic Capacitor at C2. The PCB silk screen printing features a white marking indicating where the negative (cathode) lead can be inserted. It's important to note that the shorter lead is the negative (cathode) pole, and the capacitor must be placed horizontally.



Step 18: Install 2pcs 0.1uF 104 Monolithic Capacitor at C1,C3.

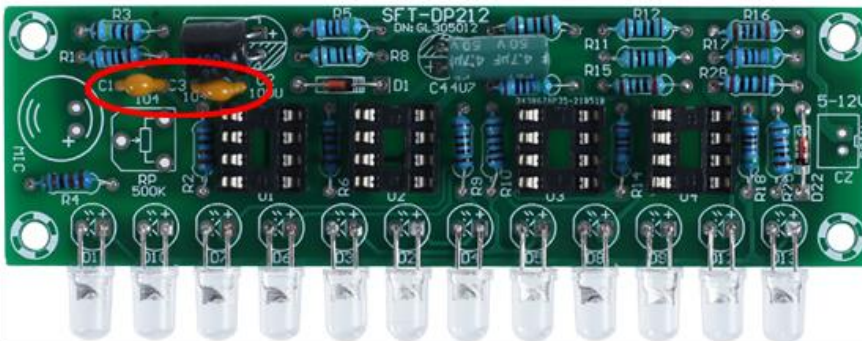

Step 19: Install 1pcs 9.7mm MIC Microphone at MIC. To differentiate between the positive and negative poles, pay attention to the marked pin, which is the negative pole

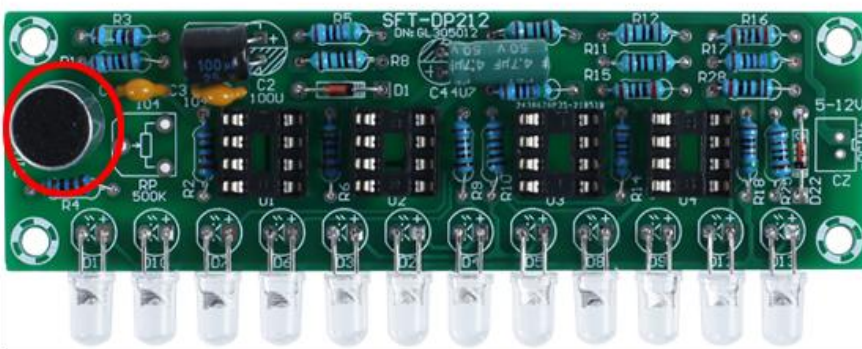



Step 20: Install 1pcs 1Mohm Potentiometer at RP.  
 Note: It needs to be installed on the other side of the PCB.



Step 21: Install 4pcs DIP-8 LM358 Amplifier at U1,U2,U3,U4. Look for a gap mark on one end of the IC and a corresponding gap mark on the DIP-8 IC Socket. These marks are used to indicate the installation direction of the IC.

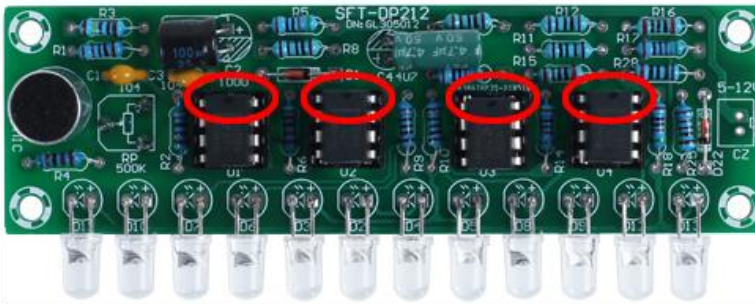

Step 22: Install 1pcs PH2.0-2P Wire at CZ on the PCB back.  
 Note: Red wire connect to ' + ' pad and black wire connect to ' - ' pad.  
 Otherwise, the LED spectrum board will be damaged.

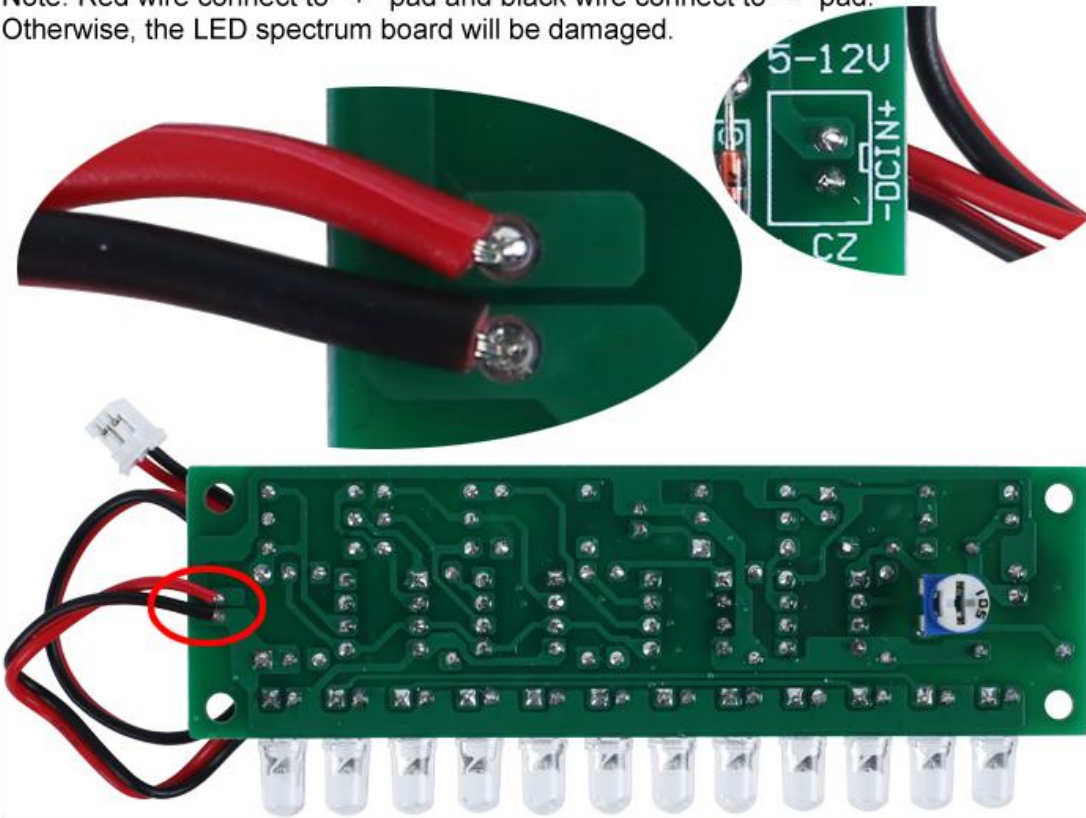

Step 23: Connect PH2.0-2P Wire to 4ohm 3W Speaker. Red wire connect to ' + ' pad.



Step 24: Tear off the protective film on the surface of the acrylic boards.



Step 25: Fix 1pcs DC-005 Power Socket by its nut on acrylic board.

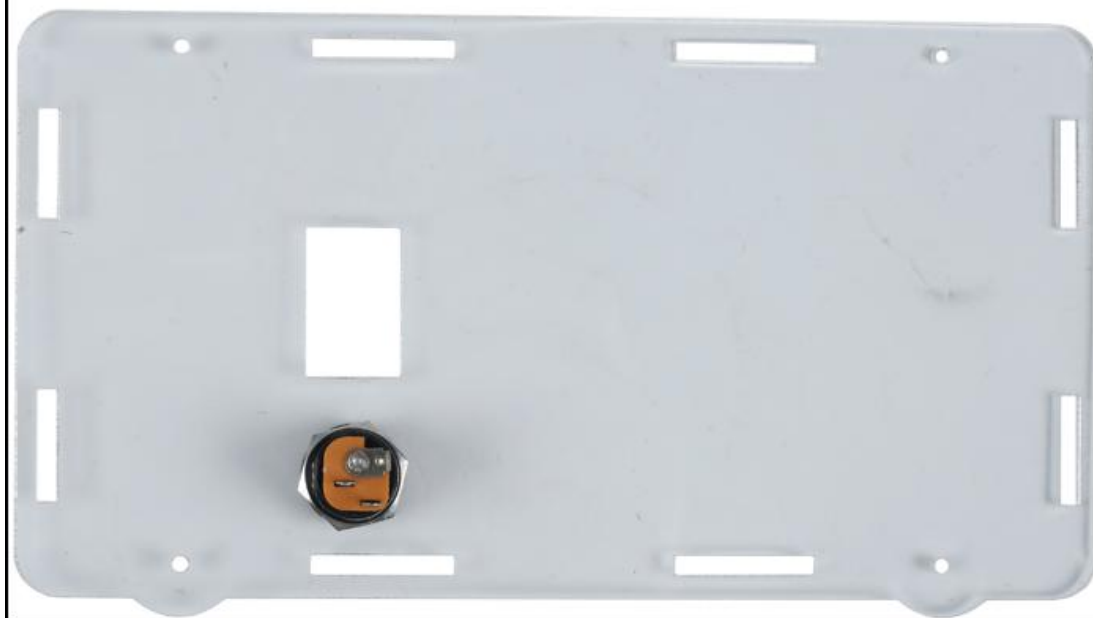

Step 26: Fix 1pcs Red/Black Switch on acrylic panel. Pay attention to the buckle on the switch, which can be fixed by itself. Pay attention to the installation direction.

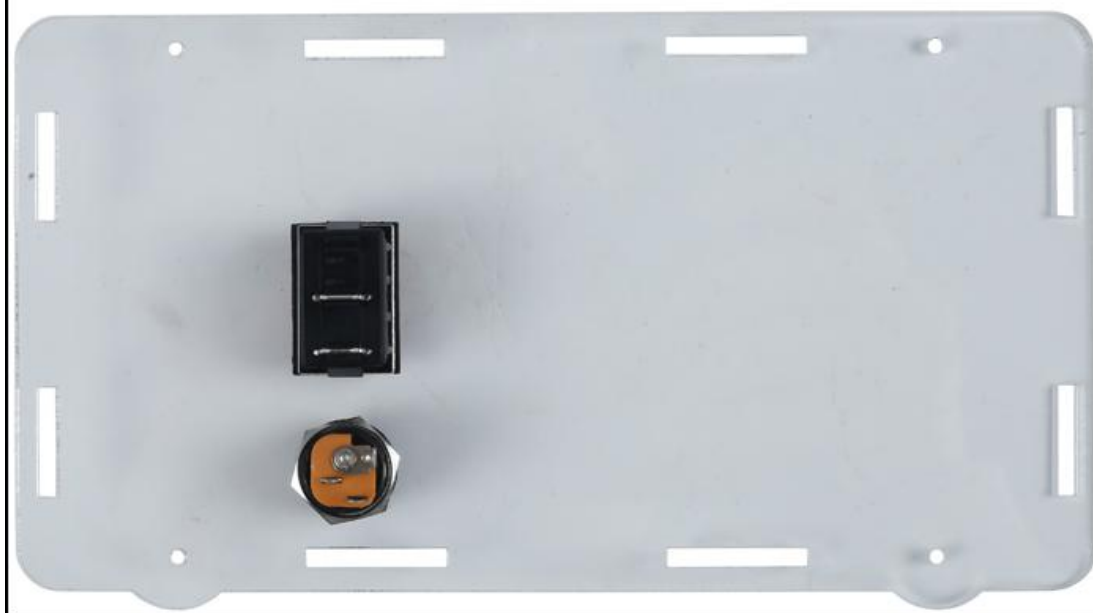



Step 27: Cut about 3cm red wire to connect DC-005 Power Socket and Red/Black Switch. Pay attention to their pin selection and can not choose to connect other pins.

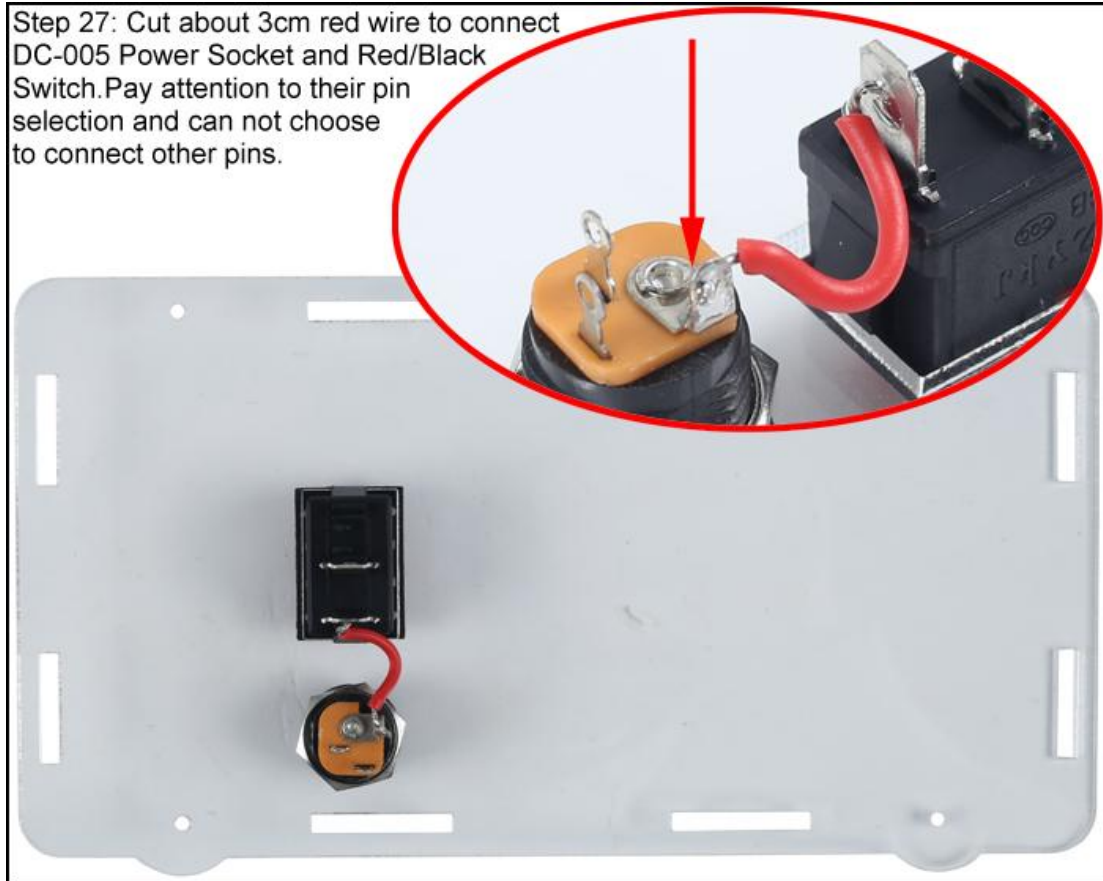

Step 28: Connect 1pcs 10cm PH2.0-2P Wire to DC-005 and Red/Black Switch. The red wire connect to Switch and the black wire connect to DC-005 Power Socket. Refer to the wiring location shown if the wire is in another color.

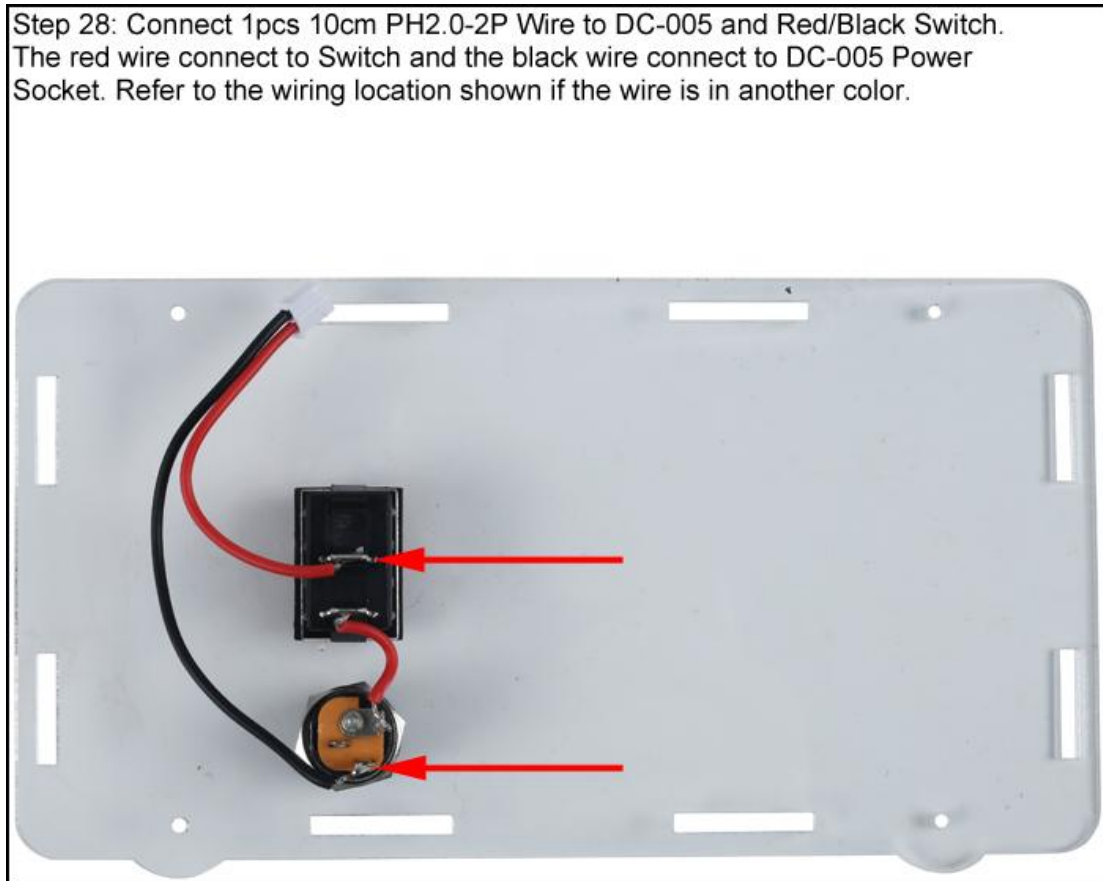

Step 29: Crimp about 3cm Wire a FM Antenna and install it on Bluetooth Receiver as shown pad.

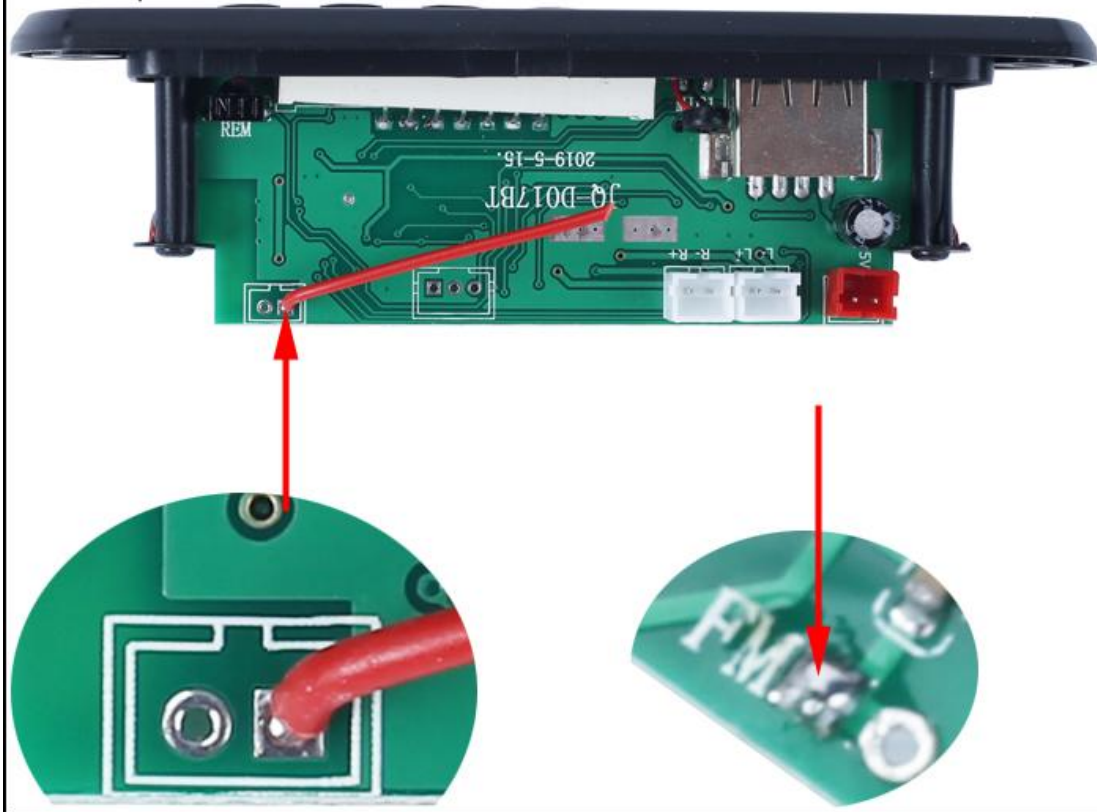

Step 30: Fix Bluetooth Receiver on another acrylic board by 2pcs M3\*6mm Screw and 2pcs M3 Nut.



Step 31: Cut PH2.0-2P Plug from LED board and connect red/black wire to Bluetooth Receiver where has marked '5V' and 'GND'.  
Note: red wire connect to '5V' pad from 'IN+' pad.

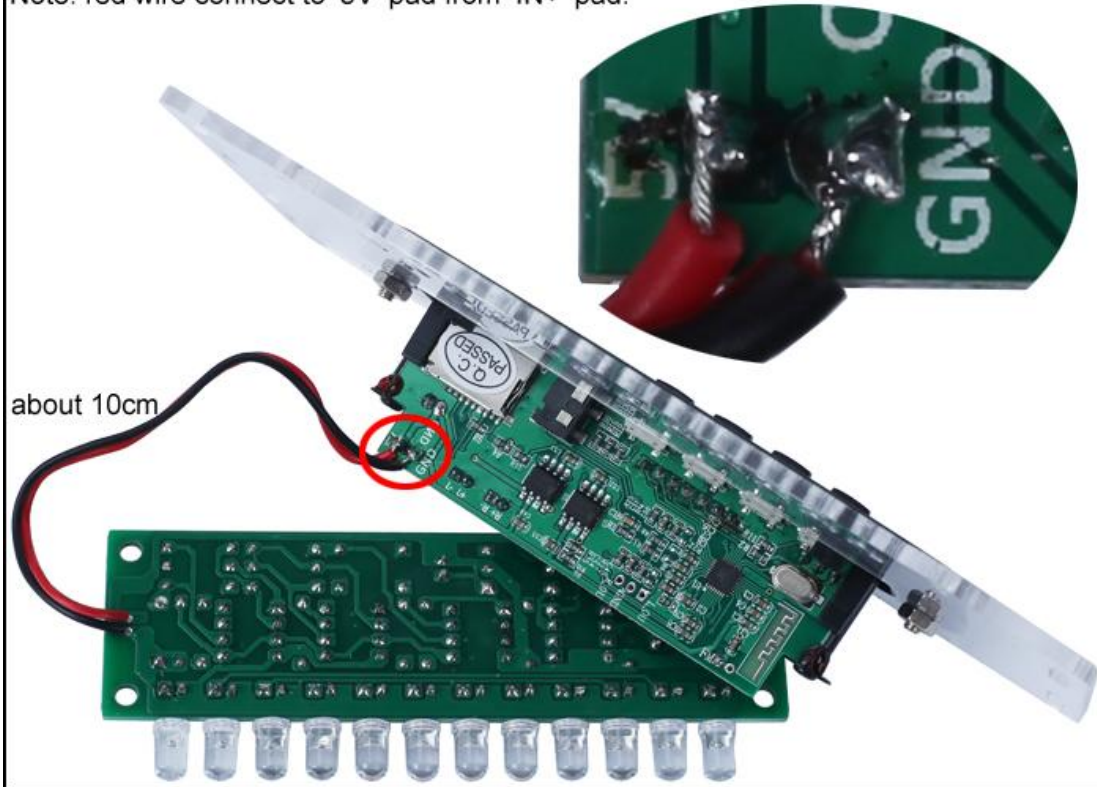

Step 32: Fix 2pcs M3\*5+6mm Copper Pillar Screw on LED board by 2pcs M3 Nut.

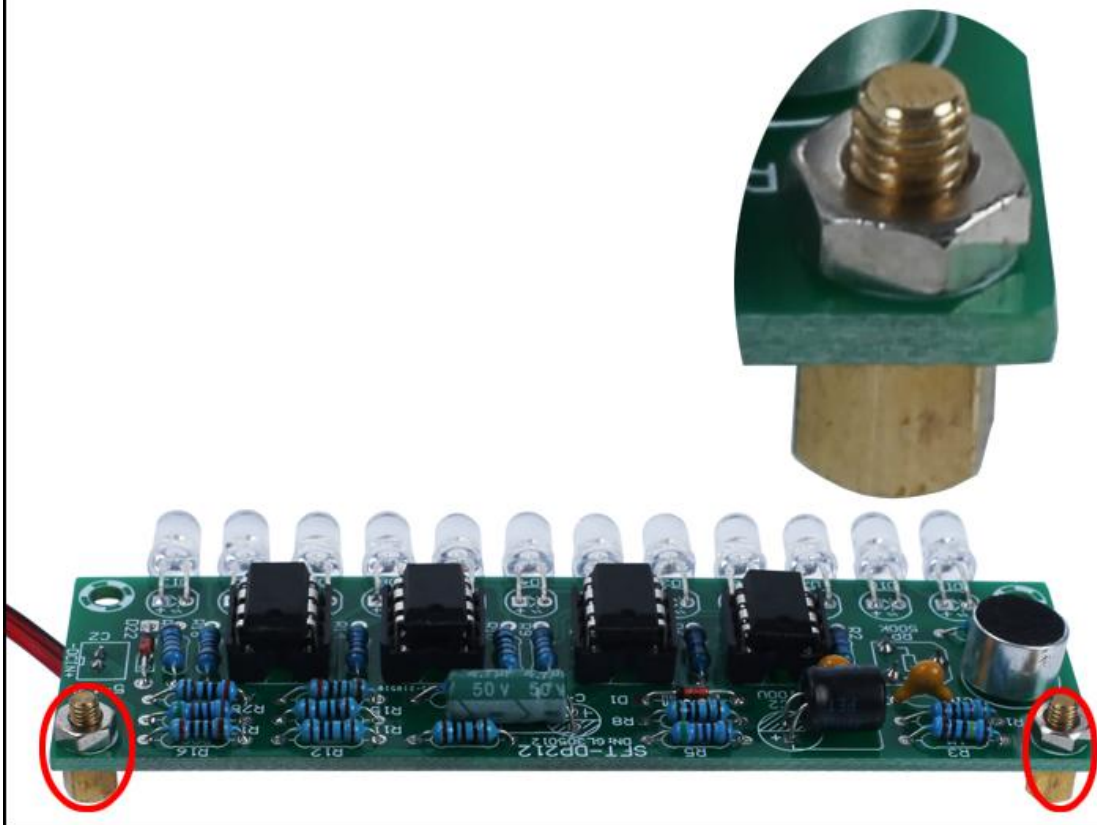



Step 33: Fix LED spectrum board on another acrylic board by 2pcs M3\*5mm Screw.

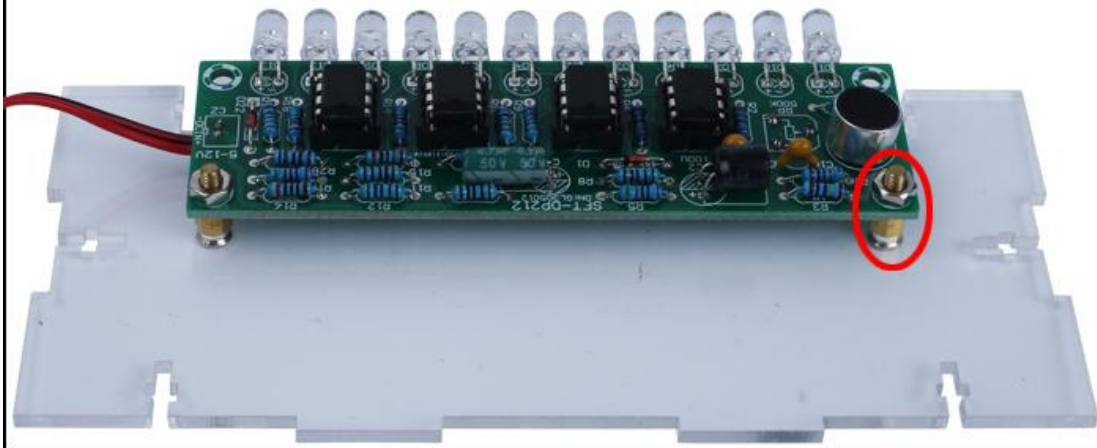

Step 34: Fix 4ohm 3W Speaker on acrylic board by 4pcs M3\*6mm Screw and 4pcs M3 Nut. Pay attention to the installation direction of screws.



Step 35: Fix 1pcs 4ohm 3W Speaker on LED acrylic board by 2pcs M2\*10mm Screw and 2pcs M2 Nut.

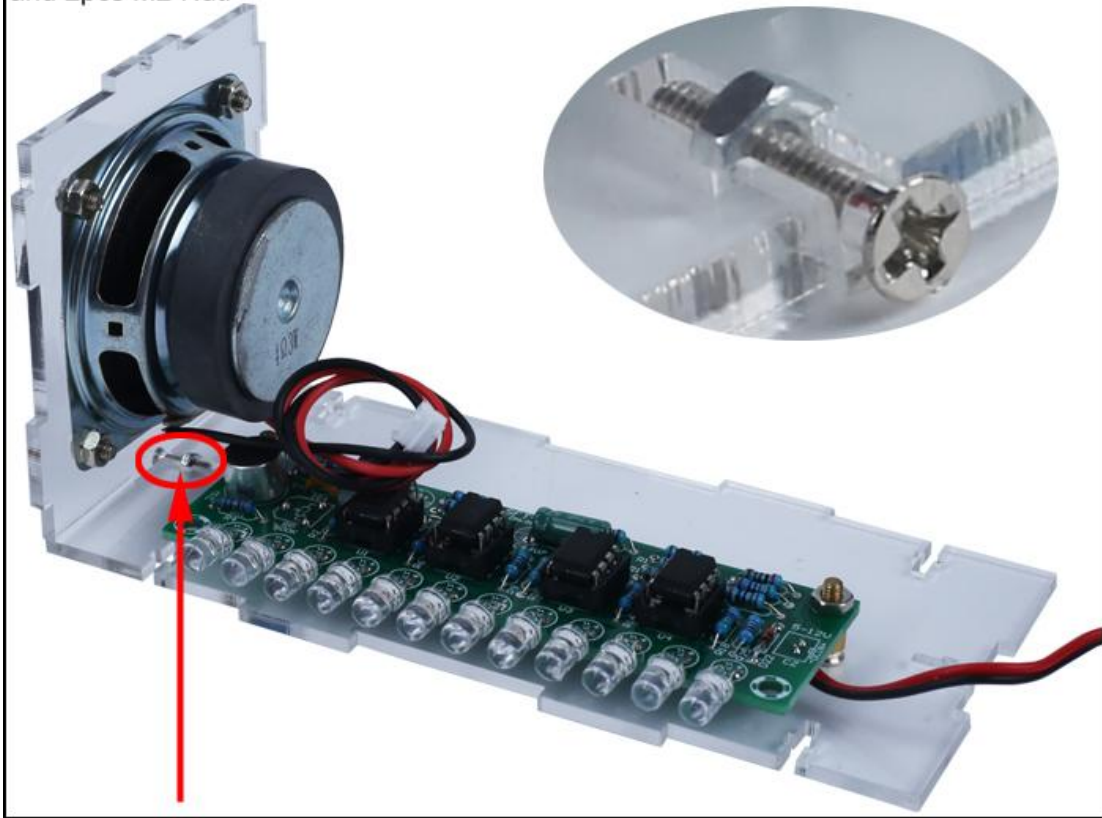

Step 36: Fix another 4ohm 3W Speaker on LED acrylic board by 2pcs M2\*10mm Screw and 2pcs M2 Nut.

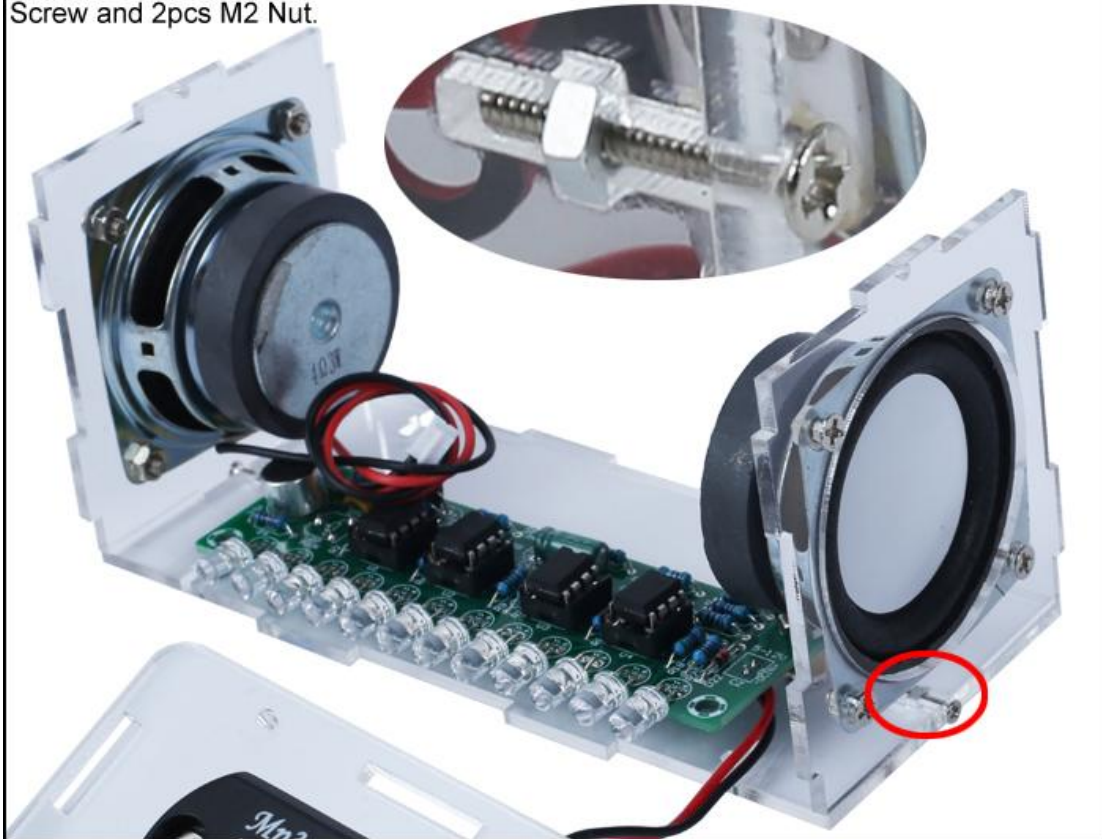

Step 37: Fix Bluetooth Receiver on LED acrylic board by 2pcs M2\*10mm Screw and 2pcs M2 Nut. Pay attention to align the mounting holes of LED and acrylic.

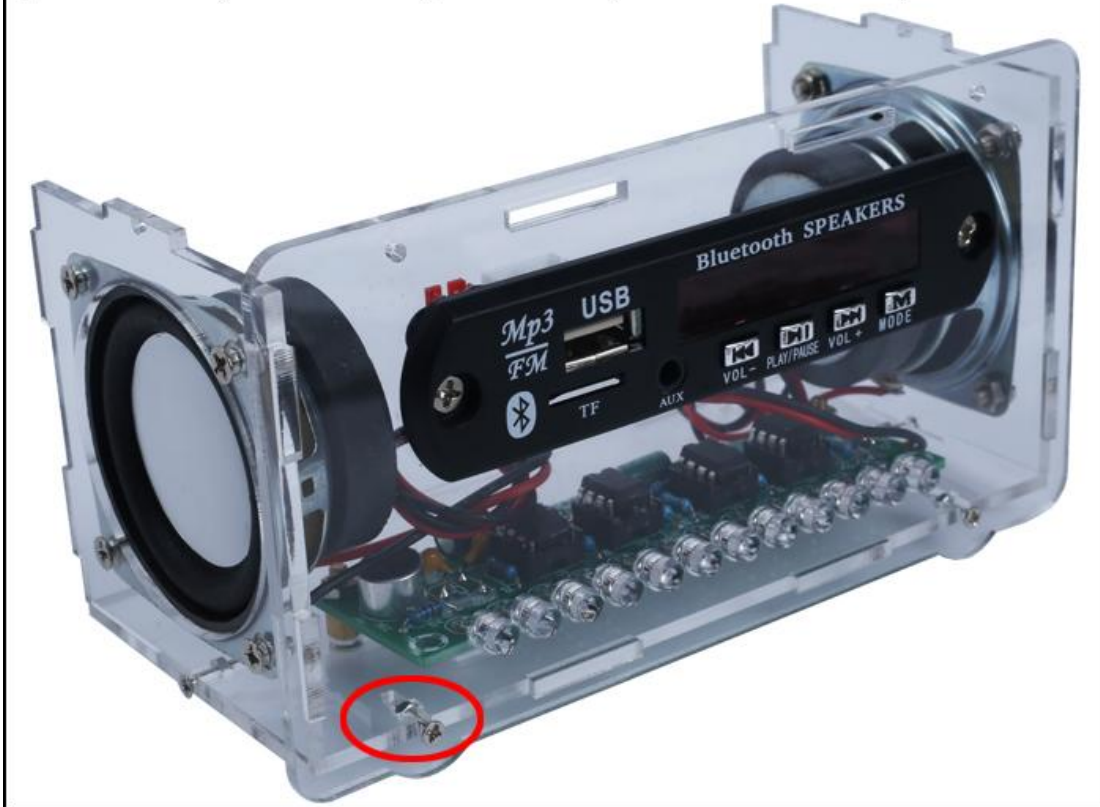

Step 38: Connect two speaker wire plug to white socket at Bluetooth Receiver.

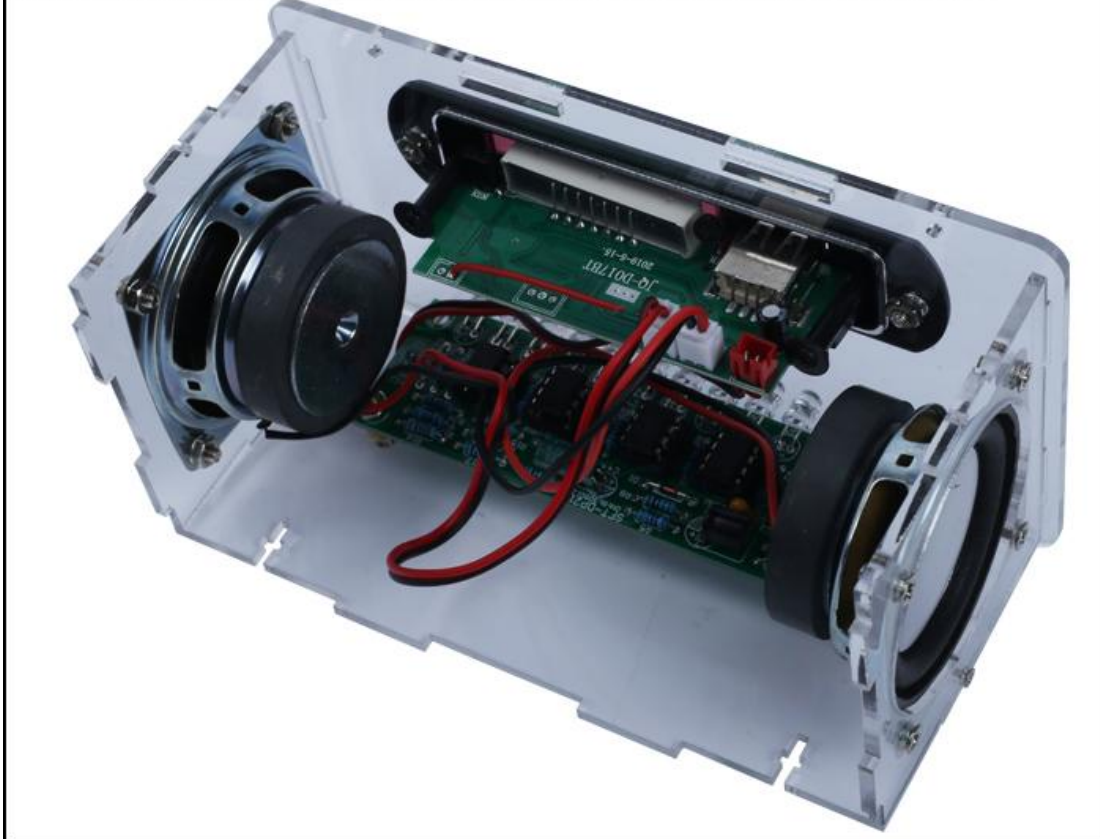



Step 39: Install another acrylic board with switch by 2pcs M2\*10mm Screw and 2pcs M2 Nut, **But don't fix it too tightly at this time.**

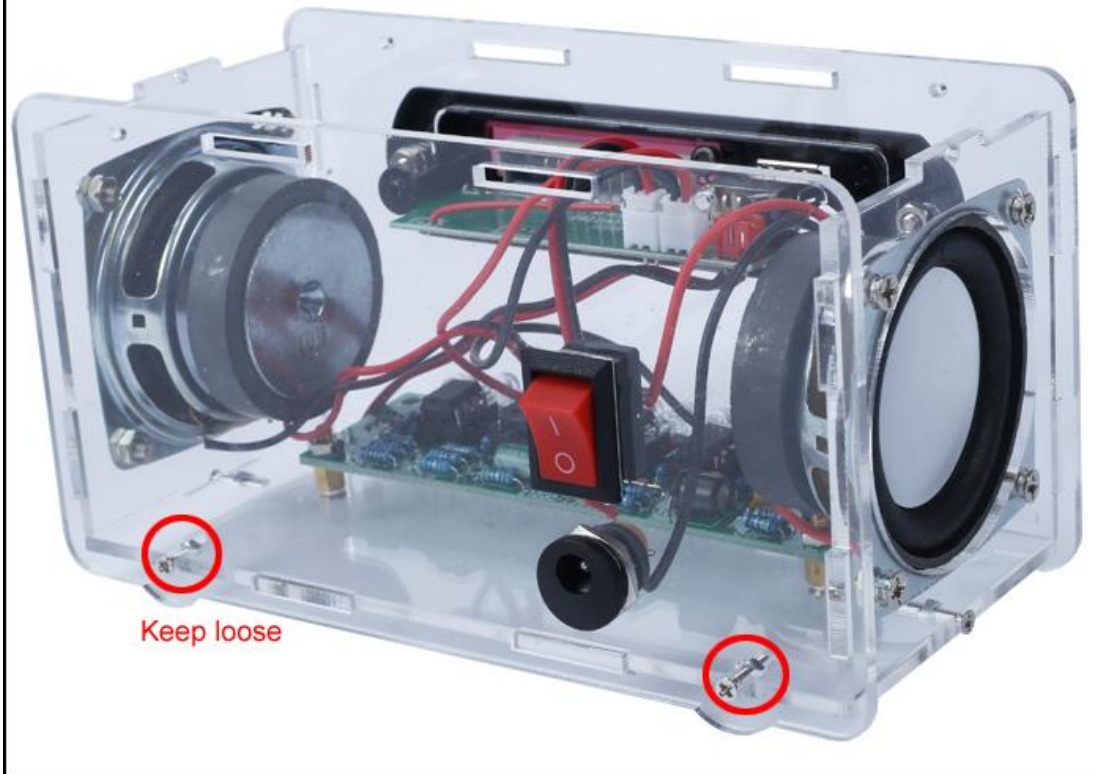

Step 40: Connect PH2.0-2P plug from Red/Black Switch to red socket on Bluetooth Receiver.  
**NOTE:** Do not have any other wires near the FM antenna to avoid interfering with the signal.

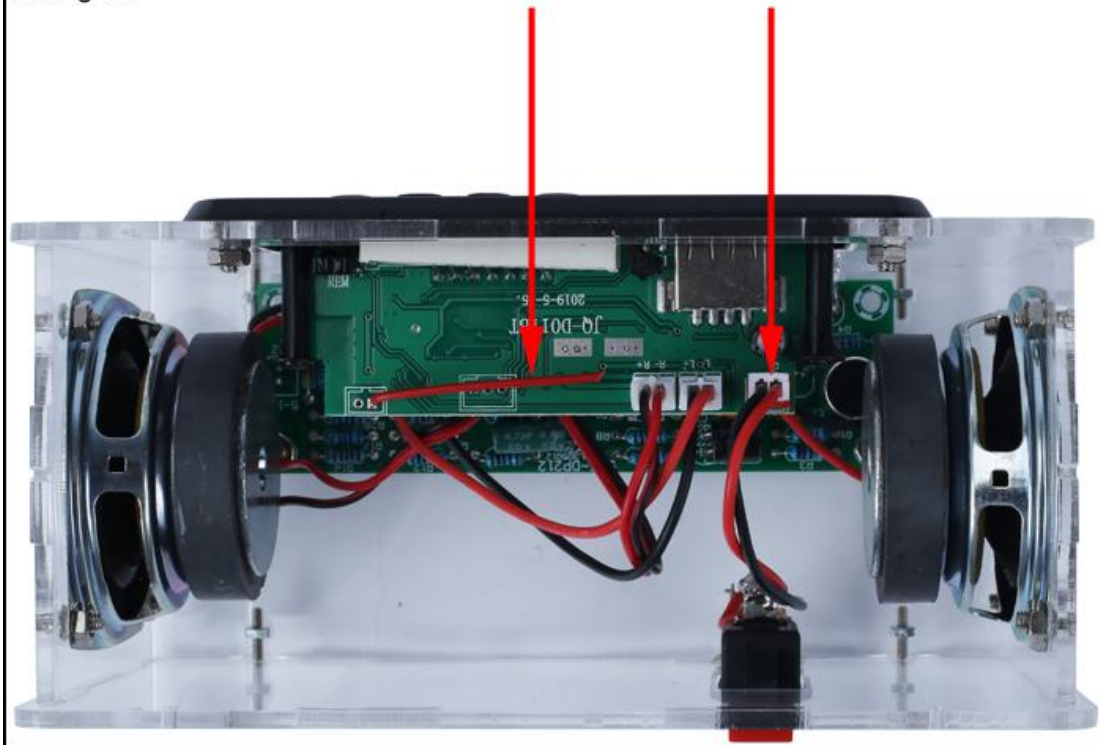

Step 41: Fix TOP acrylic board by 4pcs M2\*10mm Screw and 4pcs M2 Nut.  
And fix Screw in Step-39.

