

D2-5 Intelligent Tracking Car DIY Kit

1.Introduction:

There is a 16 mm wide black runway in the white field.Our tracking car can drive along the black runway automatically.No matter how the runway is bent, the car can be driven automatically.

We all know that the reflectivity is different when the light source to the white objects and black objects.Here we use red light source.The light is reflected through the ground to the photoresistor. By detecting the Resistor of the photosensitive resistor can determine whether the car is driving in the white area.If the detection is black runway, then the car to change the direction of driving and motor will slow down or even stop and Red LED OFF on PCB front side.Drive the car in the opposite direction so that the car is always running along the runway.

2.Feature:

- 1>.Automatic tracing motion
- 2>.Automatic intelligent control
- 3>.Circuit/mechanical/sensor professional training
- 4>.Enhance the principle of theory and Practice
- 5>.DIY manual welding

3.Parameter:

- 1>.Product Name:D2-5 Intelligent Tracking Car DIY Kit
- 2>.Work Voltage:DC 3.0V
- 3>.Work Temperature:-40°C~85°C
- 4>.Work Humidity:5%~95%RH
- 5>.Size(Installed):104*72*55mm

4.Component Listing:

NO.	Component Name	PCB Marker	Parameter	Quantity
1	LM393	IC1	DIP-8	1
2	IC Socket	IC1	DIP-8	1
3	Electrolytic Capacitor	C1,C2	100uF	2
4	Potentiometer	R1,R2	103 10K	2
5	Metal Film Resistor	R5,R6,R11,R12	51ohm	4
6	Metal Film Resistor	R7,R8	1K	2
7	Metal Film Resistor	R9,R10	10ohm	2
8	Photoresistor	R13,R14	CDS5	2
9	Red LED	D1,D2	5mm	2
10	White LED	D4,D5	5mm	2

11	S8550 Transistor	Q1,Q2	TO-92	2
12	Self-Locking switch	S1	6*6mm	1
13	DC Motor	M1,M2	JD3-100	2
14	Wheel		24mm	2
15	Tires		24mm	2
16	Axle		D2*30mm	2
17	Plastic Spacer		D2.0mm	6
18	Three-way sleeve		D2.5mm	4
19	Gear		D22mm	2
20	Worm		D5mm	2
21	Screw		D2.2*8mm	4
22	Motor Screw(Black)		D1.7*4mm	4
23	Screw		M5*20mm	1
24	Nut		M5	1
25	Screw Cap		M5	1
26	Cable		6cm	4
27	Battery Case(With adhesive)		AA*2	1
28	PCB(104*72*1.6mm)		D2-5	1

Note:Users can complete the installation according to the PCB silk screen and component list.

5.Schematic Diagram:

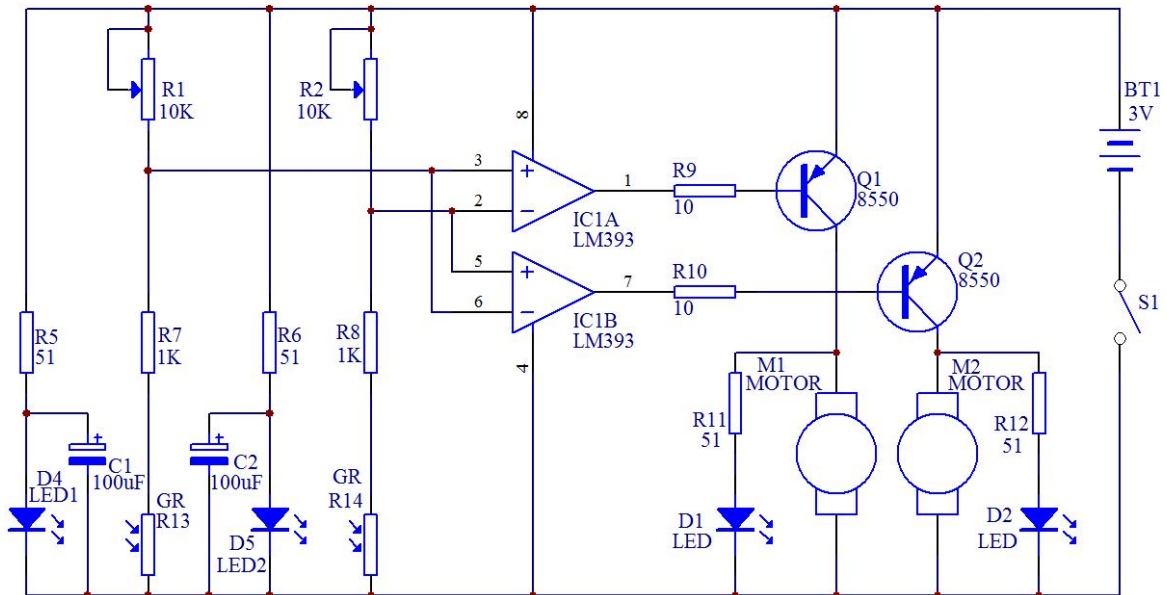

6.Application:

- 1>.Training welding skills
- 2>.Student school

- 3>.DIY production
- 4>.Project Design
- 5>.Electronic competition
- 6>.Gift giving

7.Installation Tips:

- 1>.User needs to prepare the welding tool at first.
- 2>.Please be patient until the installation is complete.
- 3>.The package is DIY kit.It need finish install by user.
- 4>.The soldering iron can't touch the components for a long time(1.0 second), otherwise it will damage the components.
- 5>.Pay attention to the positive and negative of the components.
- 6>.Strictly prohibit short circuit.
- 7>.User must install the LED according to the specified rules.Otherwise some LED will not light.
- 8>.Install complex components preferentially.
- 9>.Make sure all components are in right direction and right place.
- 10>.It is strongly recommended to read the installation manual before starting installation!!!
- 11>.Please wear anti-static gloves or anti-static wristbands when installing electronic components.

8.Installation Steps(Please be patient install!!!):

- 1>.Step 1: Install 4pcs 51ohm Metal Film Resistor at R5,R6,R11,R12.
- 2>.Step 2: Install 2pcs 10ohm Metal Film Resistor at R9,R10.
- 3>.Step 3: Install 2pcs 1K Metal Film Resistor at R7,R8.
- 4>.Step 4: Install 1pcs DIP-8 IC Socket at IC1.There is a mark on one end of the IC Socket and there is a mark on PCB where the IC can place on.These two marks are corresponding to each other and are used to specify the installation direction of the IC Socket.
- 5>.Step 5: Install 2pcs TO-92 S8550 Transistor at Q1,Q2.Pay attention to the installation direction.
- 6>.Step 6: Identify the positive and negative poles of LED and Electrolytic Capacitor.The longer pin is inserted into the rectangular pad(positive pole). The shorter pins are inserted into the round pads.
- 7>.Step 7: Install 2pcs 5mm Red LED at D1,D2.Pay attention to distinguish between positive and negative.The larger metal plate is the negative pole inside the LED.The shorter pin is negative pole.
- 8>.Step 8: Install 2pcs 10K Potentiometer at R1,R2.
- 9>.Step 9: Install 2pcs 100uF Electrolytic Capacitor at C1,C2.Pay attention to distinguish between positive and negative.The shorter pin is negative pole.
- 10>.Step 10: Install 1pcs 6*6mm Self-Locking switch at S1.

11>.Step 11: Install 2pcs CDS5 Photoresistor at R13,R14 on PCB's another side.Note:Make sure Photoresistor's height is about 5mm.

12>.Step 12: Install 2pcs 5mm White LED at D4,D5 on PCB's another side.Note:Make sure LED's height is about 14mm.Pay attention to distinguish between positive and negative.The larger metal plate is the negative pole inside the LED.The shorter pin is negative pole.

13>.Step 13: Install front support pillar by 1pcs M5*20mm Screw, 1pcs M5 Nut and 1pcs M5 Screw Cap.

14>.Step 14: Install 4pcs D2.0mm Yellow Plastic Spacer by 4pcs D2.2*8mm Screw.Pay attention to the installation direction of PCB.Note:Don't fix them for the time being.

15>.Step 15: Insert 1pcs D2*30mm Axle from the center hole of the D24mm Wheel.Note that the direction is inserted from one side of the raised sleeve of the wheel.

16>.Step 16: Insert 1pcs D2.5mm Three-way Sleeve on D2*30mm Axle and close to the D24mm Wheel.

17>.Step 17: Insert 1pcs D2.0mm Plastic Spacer on D2*30mm Axle and close to the D2.5mm Three-way Sleeve.

18>.Step 18: Insert 1pcs D22mm Gear on D2*30mm Axle and close to the D2.0mm Plastic Spacer.Note:The raised smaller gear is on the side away from the Plastic Spacer.

19>.Step 19: Install 1pcs D2.5mm Three-way Sleeve at the end of D2*30mm Axle.

20>.Step 20: Install 1pcs D24mm Tires on D24mm Wheel.

21>.Step 21: Assemble another wheel according to Step 15 ~ Step 20.

22>.Step 22: Install and fix 2pcs JD3-100 DC Motor at M1,M2 by 4pcs D1.7*4mm Black Motor Screw. Pay attention to the installation direction of the motor.

23>.Step 23: Install 2pcs D5mm Worm on motor shaft.

24>.Step 24: Adjust the screw to facilitate subsequent installation(That has be install at Step 14)

25>.Step 25: Fix the 2pcs assembled wheel on 4pcs D2.0mm Yellow Plastic Spacer.Adjust the distance between the accessories according to the actual situation.

26>.Step 26: Connect 2pcs motor to PCB by 4pcs 6cm cable.Pay attention to the installation sequence of cables and otherwise the car may move abnormally.

27>.Step 27: Install and fix 1pcs AA*2 Battery Case.

28>.Step 28: Tear off the protective film on the back of the battery box and then paste the battery box on the surface of PCB and pay attention to the wire.

29>.Step 29: Install 1pcs DIP-8 LM393 at IC Socket.There is a mark on one end of the IC and there is a mark on PCB where the IC can place on.These two marks are corresponding to each other and are used to specify the installation direction of the IC.

30>.Step 30: Installation Fault debugging:

30.1>.Install 2pcs AA Battery(Users need to prepare for themselves);

30.2>.Turn ON switch.It is OK if 2pcs Red LED turn ON.Otherwise, the red LED may be installed incorrectly.

30.3>.The connection sequence of the motor wires needs to be exchanged if the rotation direction of the motor is wrong.

30.4>.The adjusting potentiometer is used to change the detection distance of the photosensitive sensor.

31>.Step 31: Connect to power supply and enjoy the effect.

9.Install shown steps:

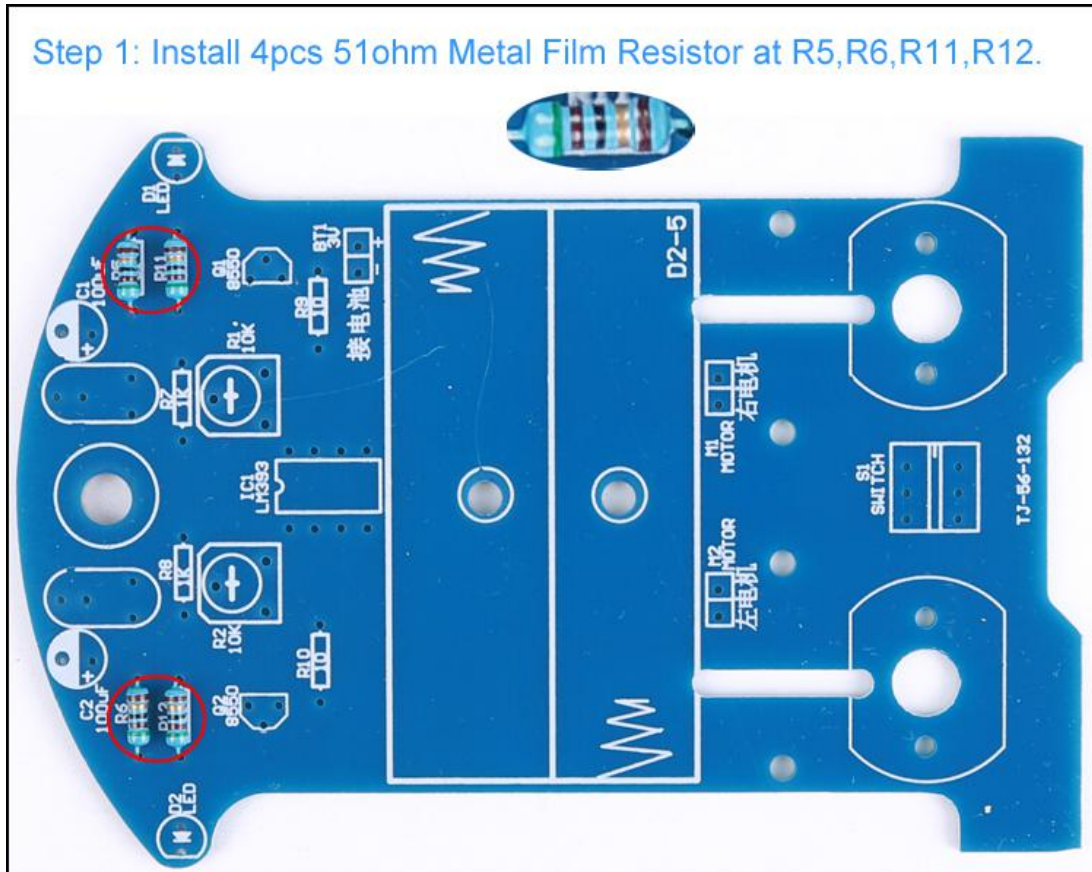

Step 2: Install 2pcs 10ohm Metal Film Resistor at R9,R10.

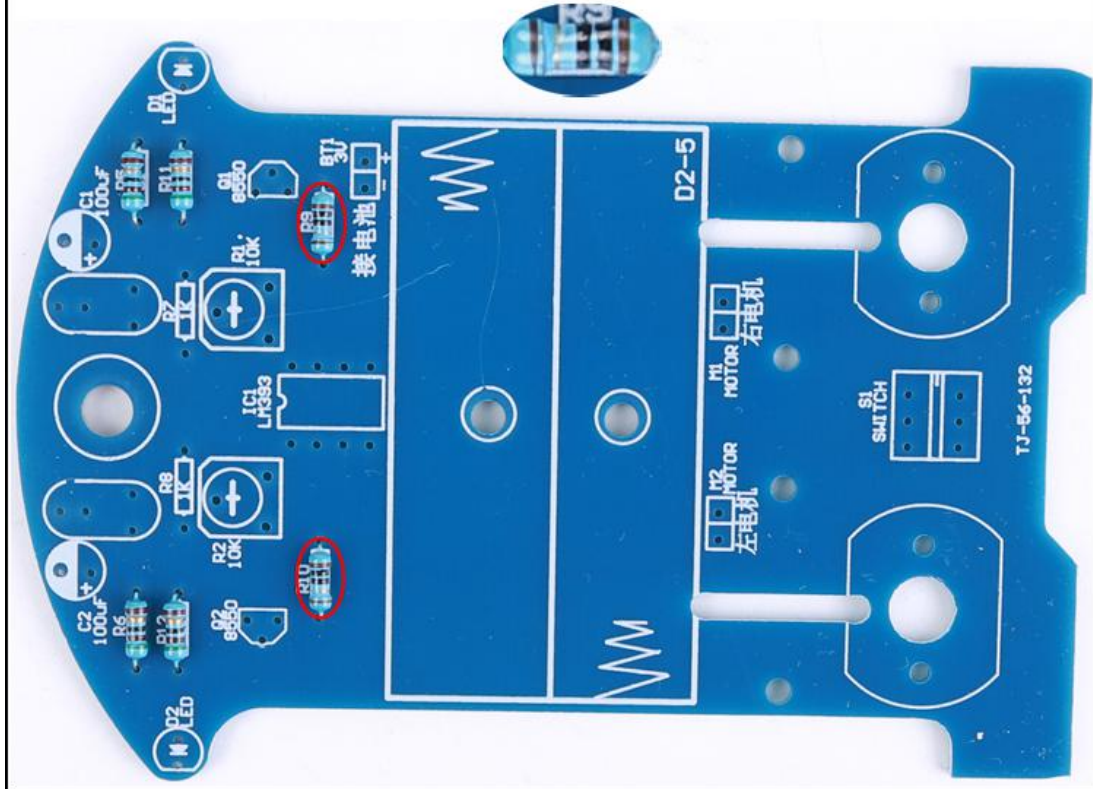

Step 3: Install 2pcs 1K Metal Film Resistor at R7,R8.

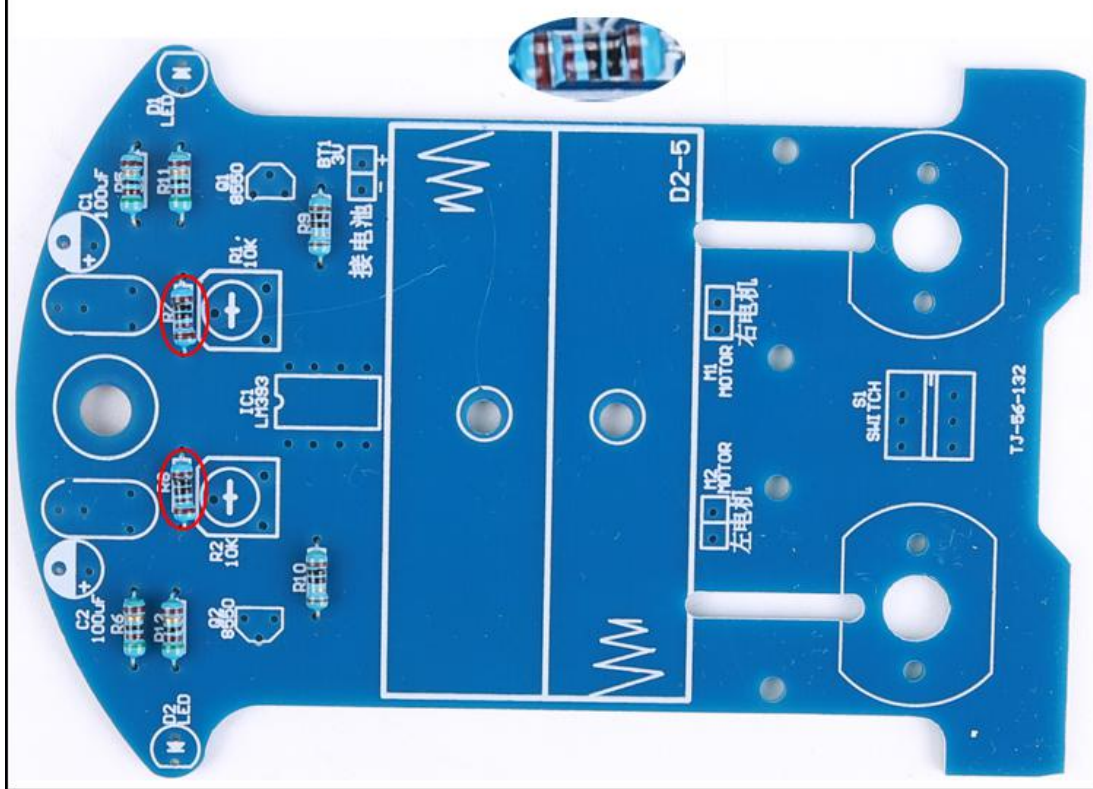

Step 4: Install 1pcs DIP-8 IC Socket at IC1. There is a mark on one end of the IC Socket and there is a mark on PCB where the IC can place on. These two marks are corresponding to each other and are used to specify the installation direction of the IC Socket.

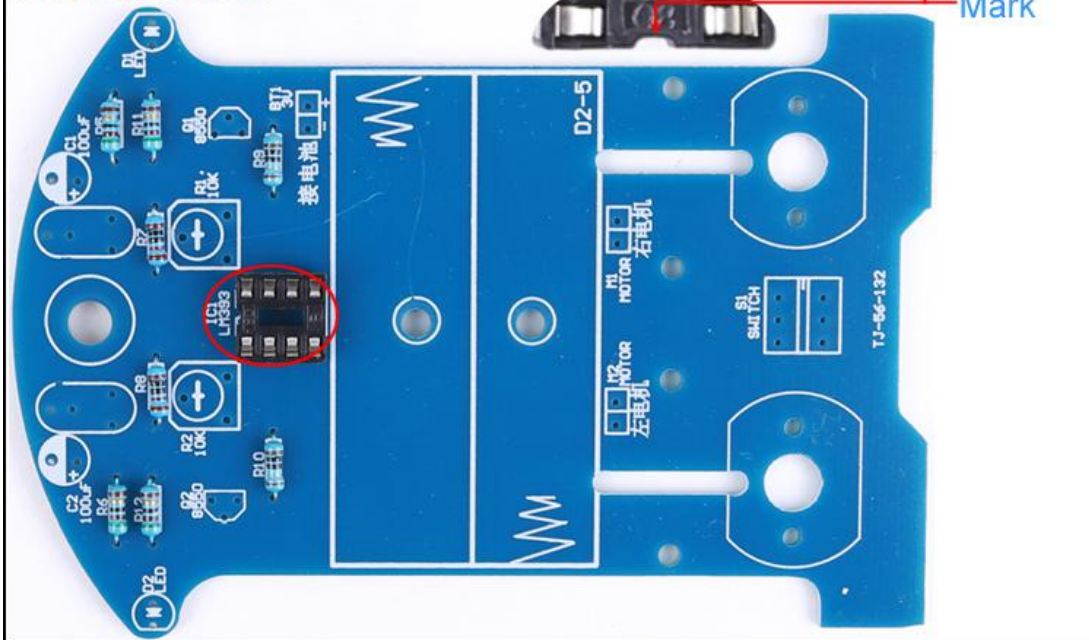

Step 5: Install 2pcs TO-92 S8550 Transistor at Q1,Q2. Pay attention to the installation direction.

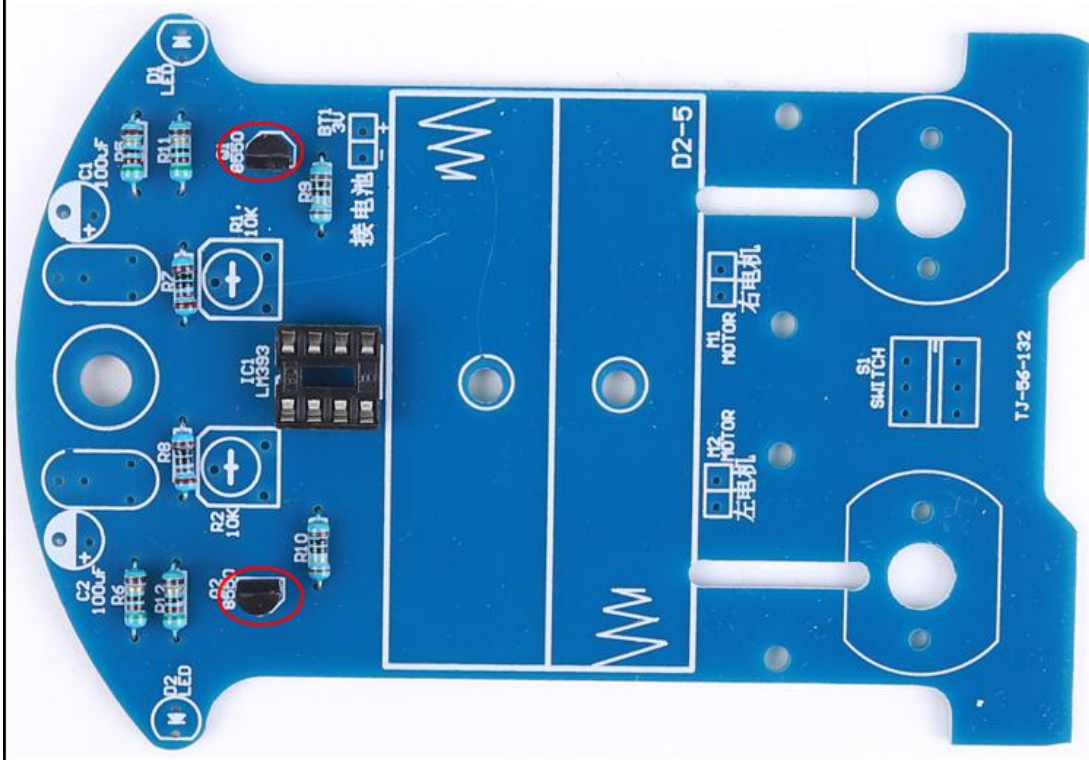

Step 6: Identify the positive and negative poles of LED and Electrolytic Capacitor. The longer pin is inserted into the rectangular pad(positive pole). The shorter pins are inserted into the round pads.

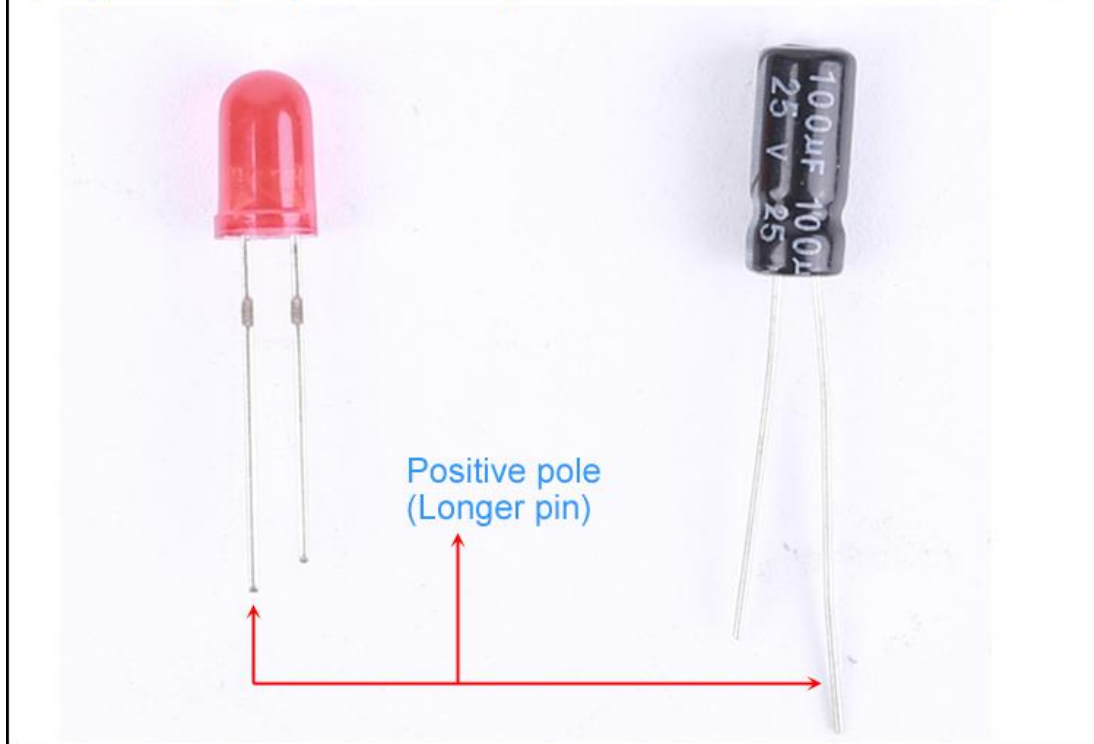

Step 7: Install 2pcs 5mm Red LED at D1,D2. Pay attention to distinguish between positive and negative. The larger metal plate is the negative pole inside the LED.

The shorter pin is negative pole.

Non arc edge (negative pole)

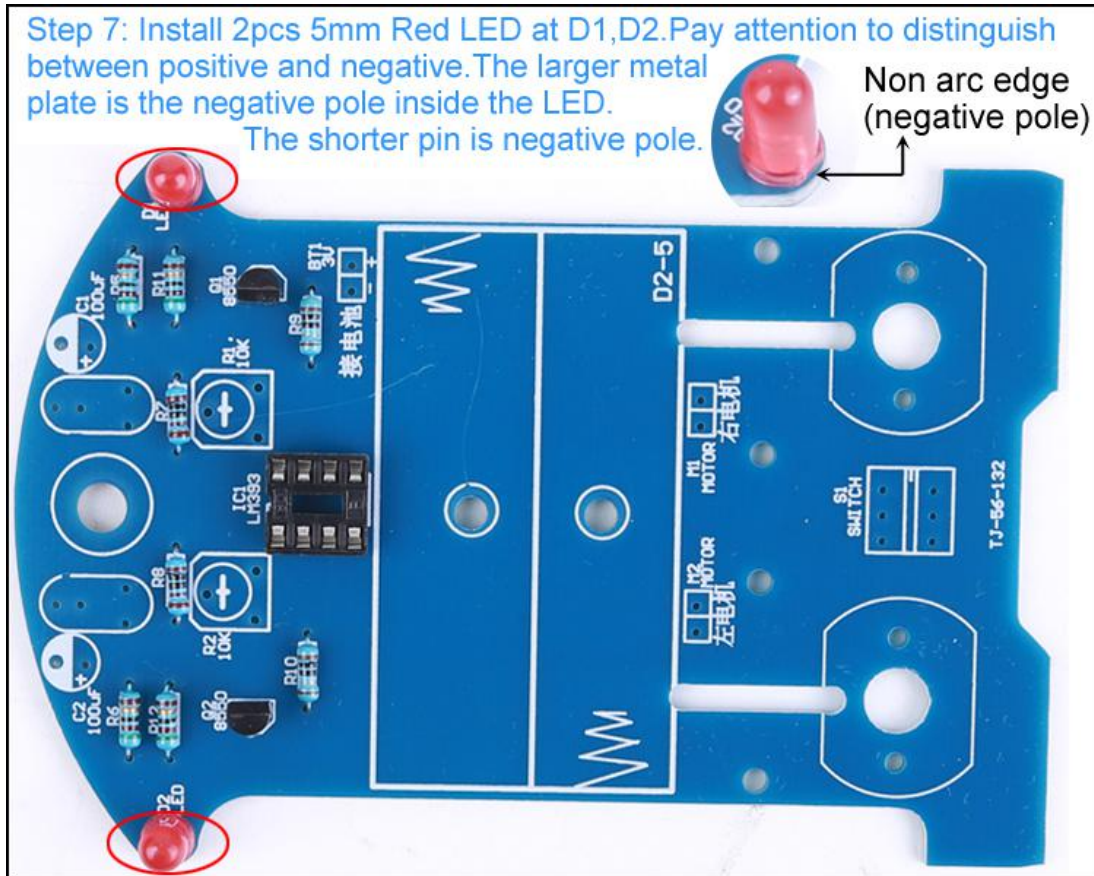

Step 8: Install 2pcs 10K Potentiometer at R1,R2.

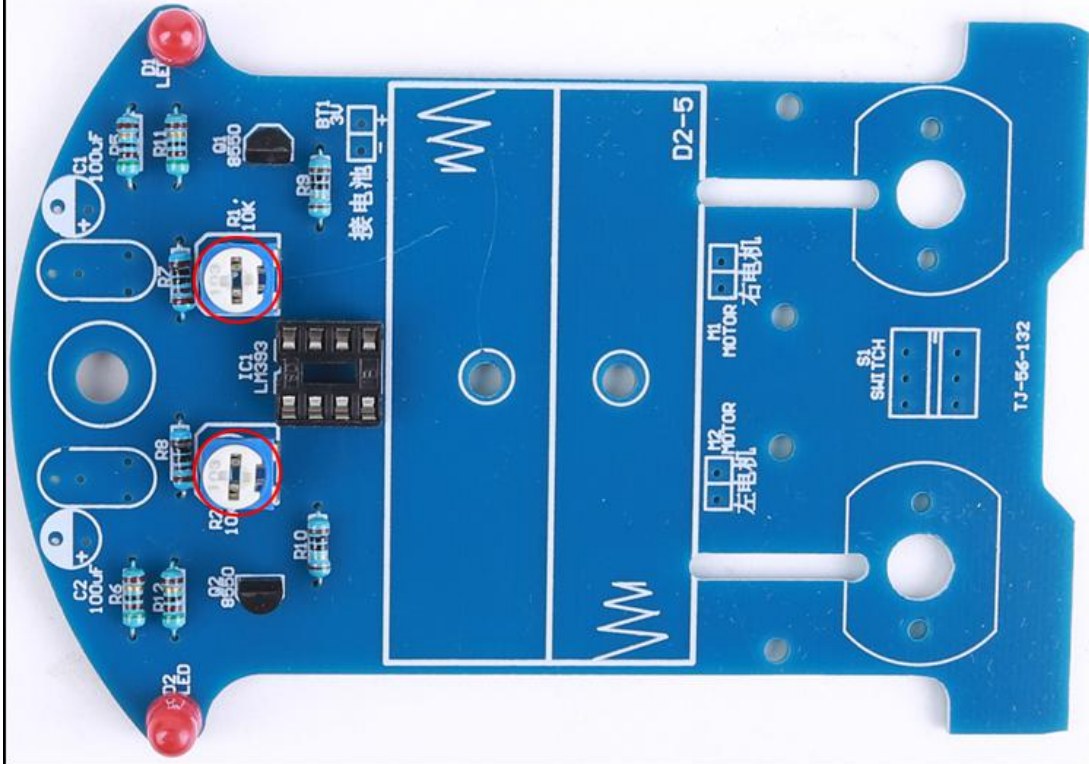

Step 9: Install 2pcs 100uF Electrolytic Capacitor at C1,C2. Pay attention to distinguish between positive and negative. The Longer pin is positive pole.

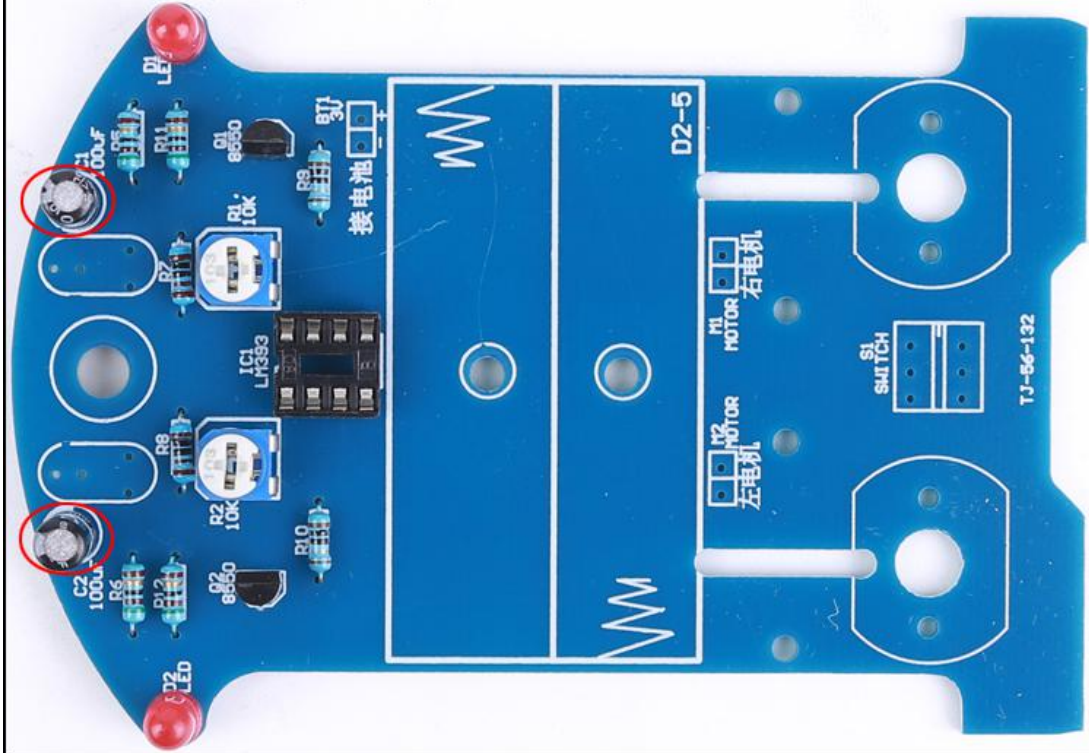

Step 10: Install 1pcs 6*6mm Self-Locking switch at S1.

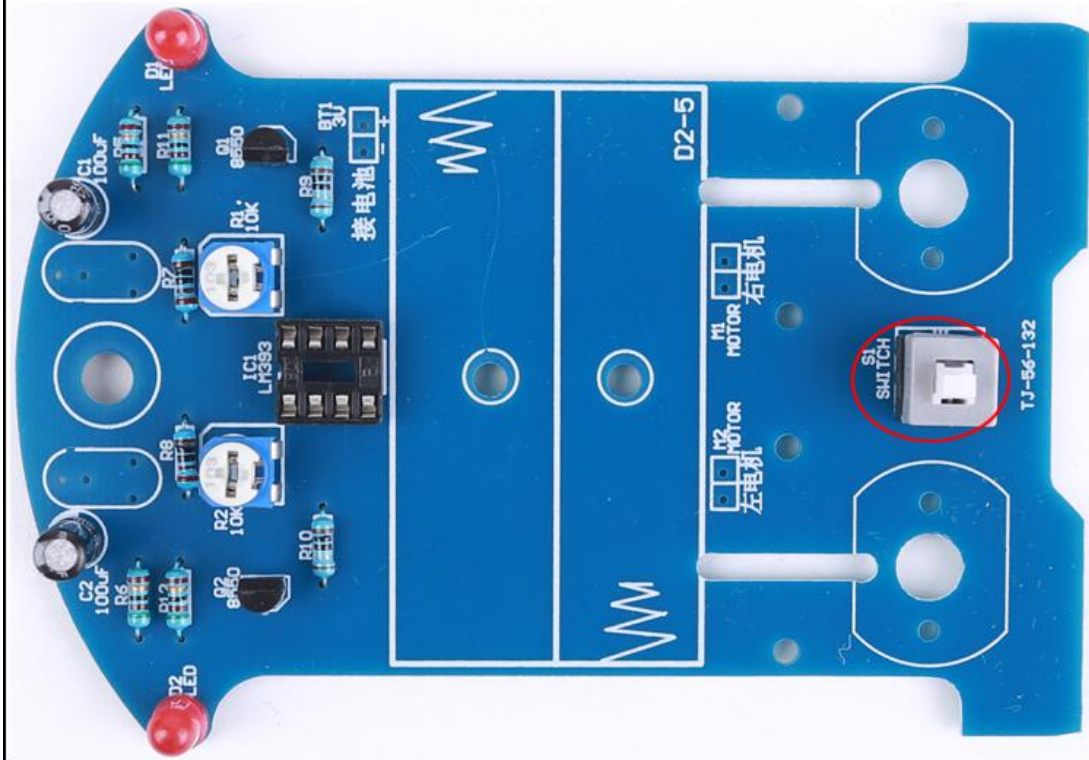

Step 11: Install 2pcs CDS5 Photoresistor at R13,R14 on PCB's another side. Note: Make sure Photoresistor's height is about 7mm.

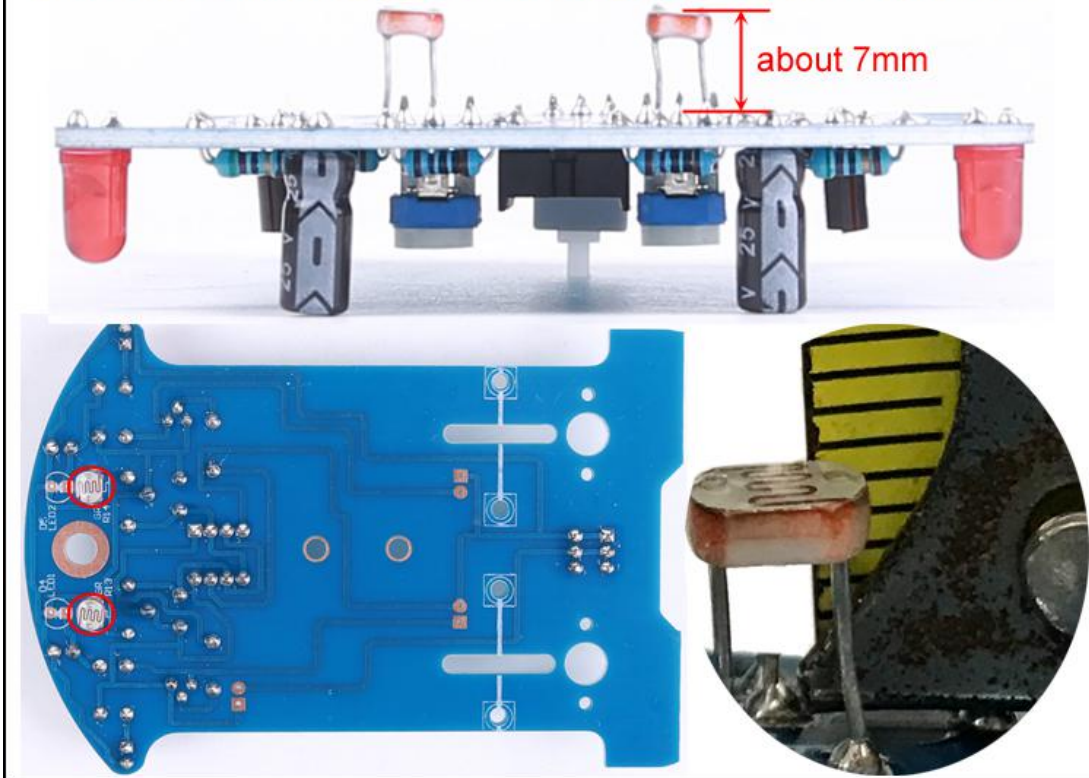

Step 12: Install 2pcs 5mm White LED at D4,D5 on PCB's another side.
 Note: Make sure LED's height is about 14mm. Pay attention to distinguish between positive and negative. The larger metal plate is the negative pole inside the LED. The shorter pin is negative pole.

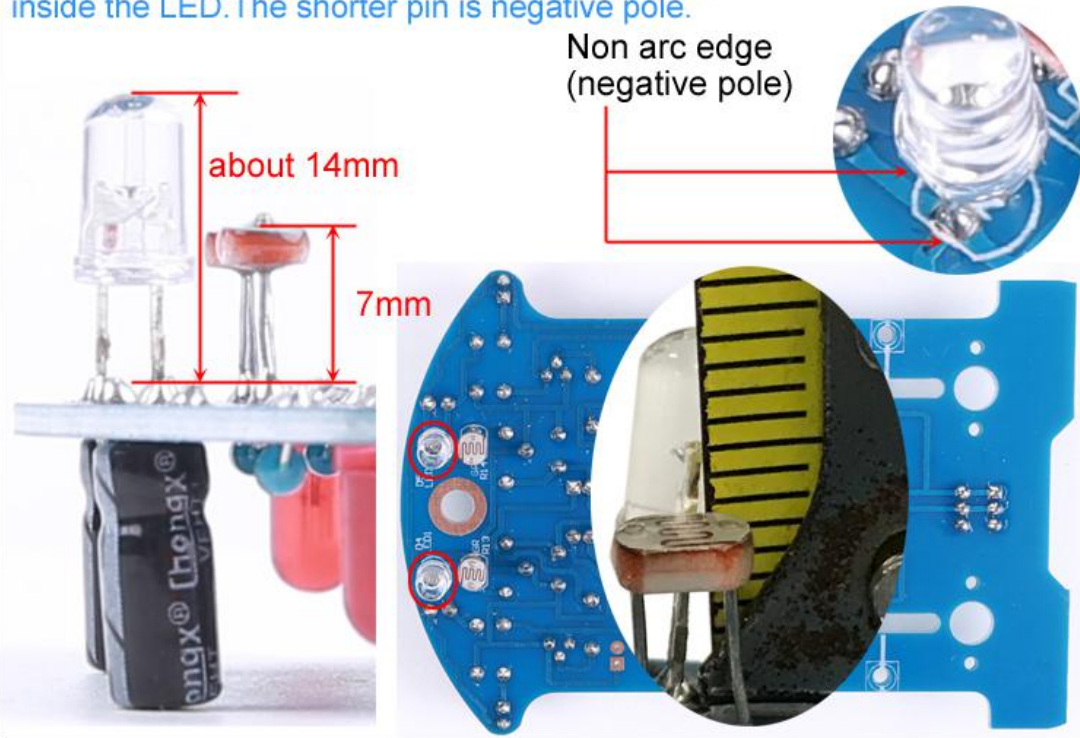

Step 13: Install front support pillar by 1pcs M5*20mm Screw, 1pcs M5 Nut and 1pcs M5 Screw Cap.

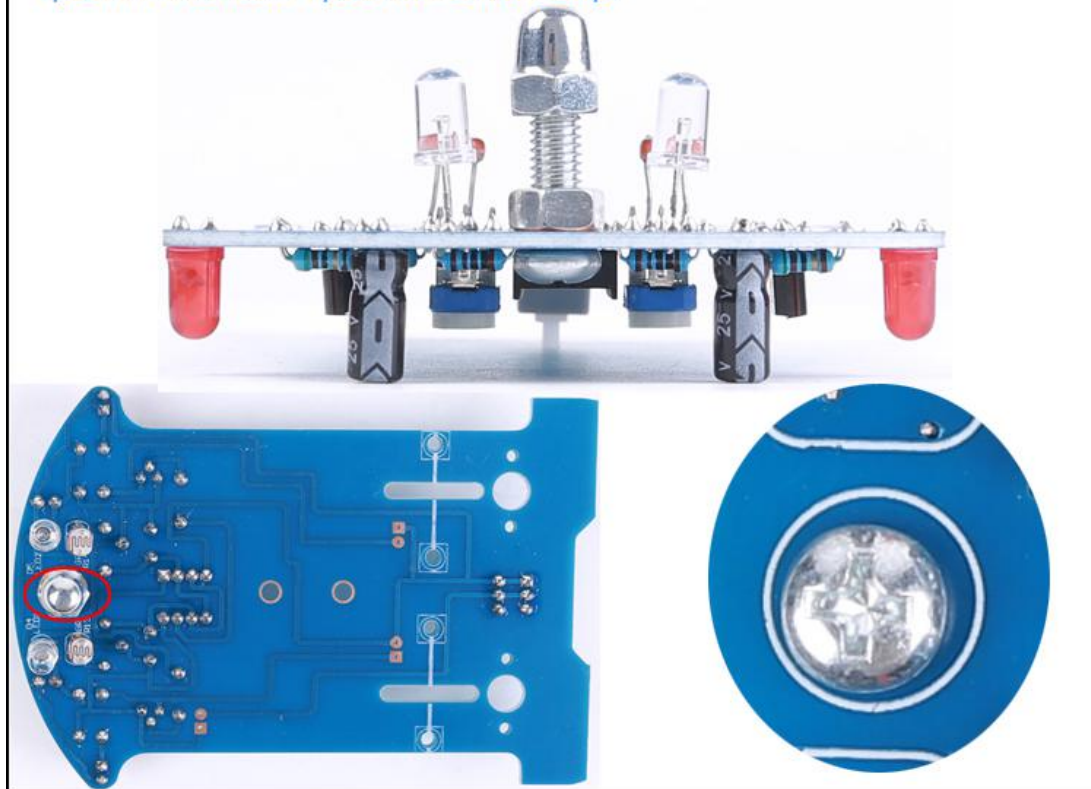

Step14: Install 4pcs D2.0mm Yellow Plastic Spacer by 4pcs D2.2*8mm Screw. Pay attention to the installation direction of PCB. Note: Don't fix them for the time being.

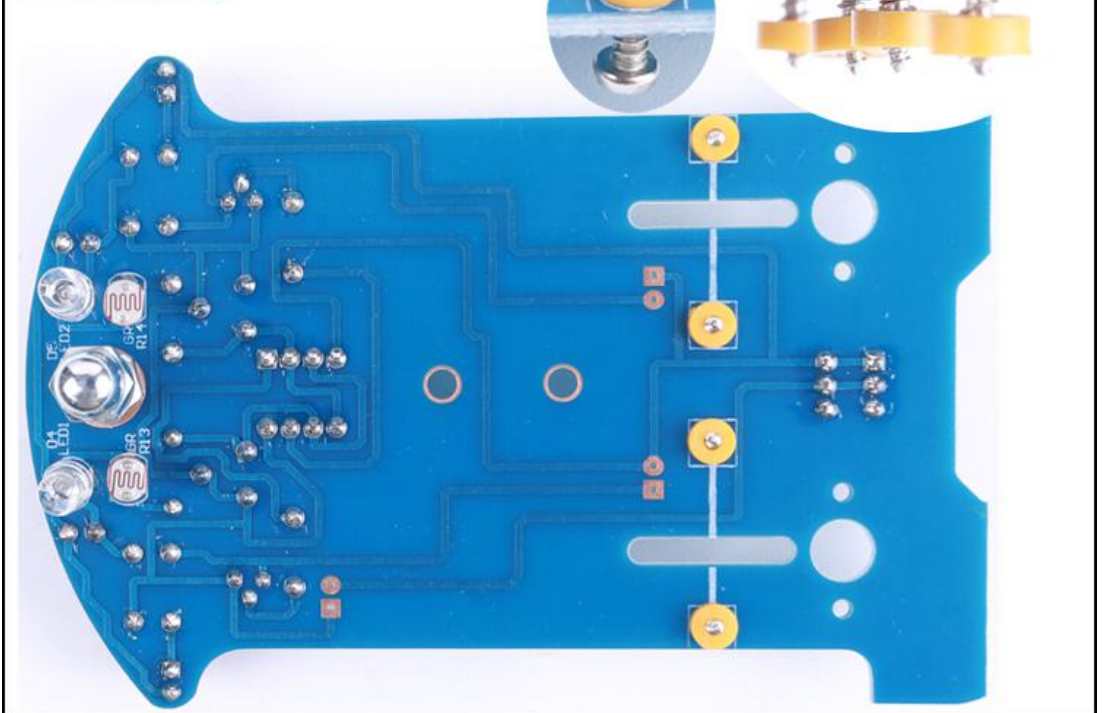

Step 15: Insert 1pcs D2*30mm Axle from the center hole of the D24mm Wheel. Note that the direction is inserted from one side of the raised sleeve of the wheel.

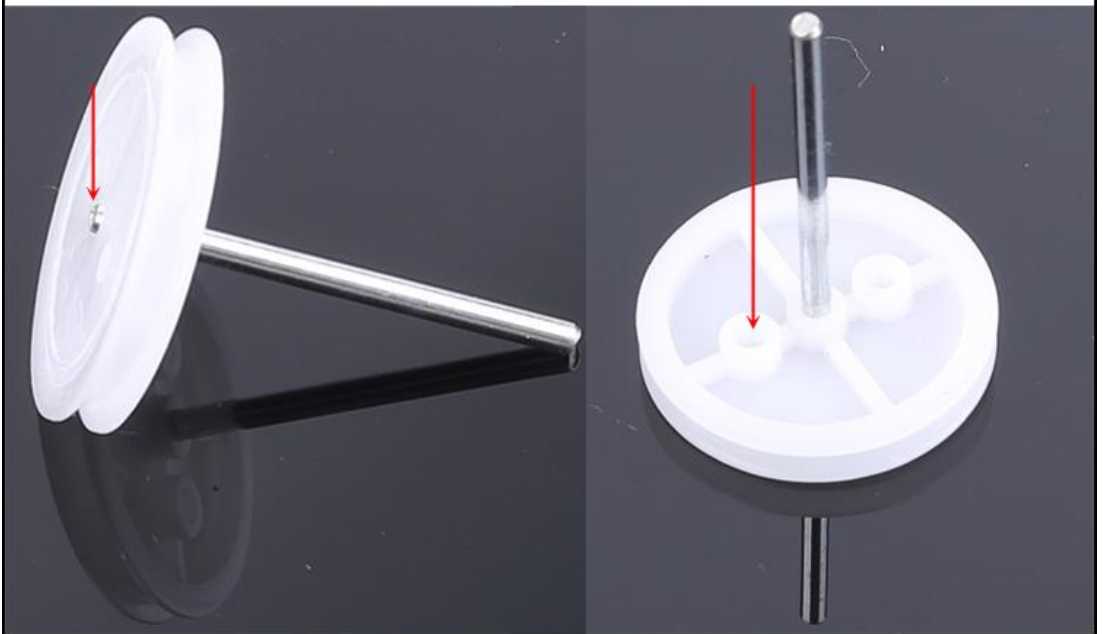

Step 16: Insert 1pcs D2.5mm Three-way Sleeve on D2*30mm Axle and close to the D24mm Wheel.



Step 17: Insert 1pcs D2.0mm Plastic Spacer on D2*30mm Axle and close to the D2.5mm Three-way Sleeve.



Step 18: Insert 1pcs D22mm Gear on D2*30mm Axle and close to the D2.0mm Plastic Spacer. Note: The raised smaller gear is on the side away from the Plastic Spacer.

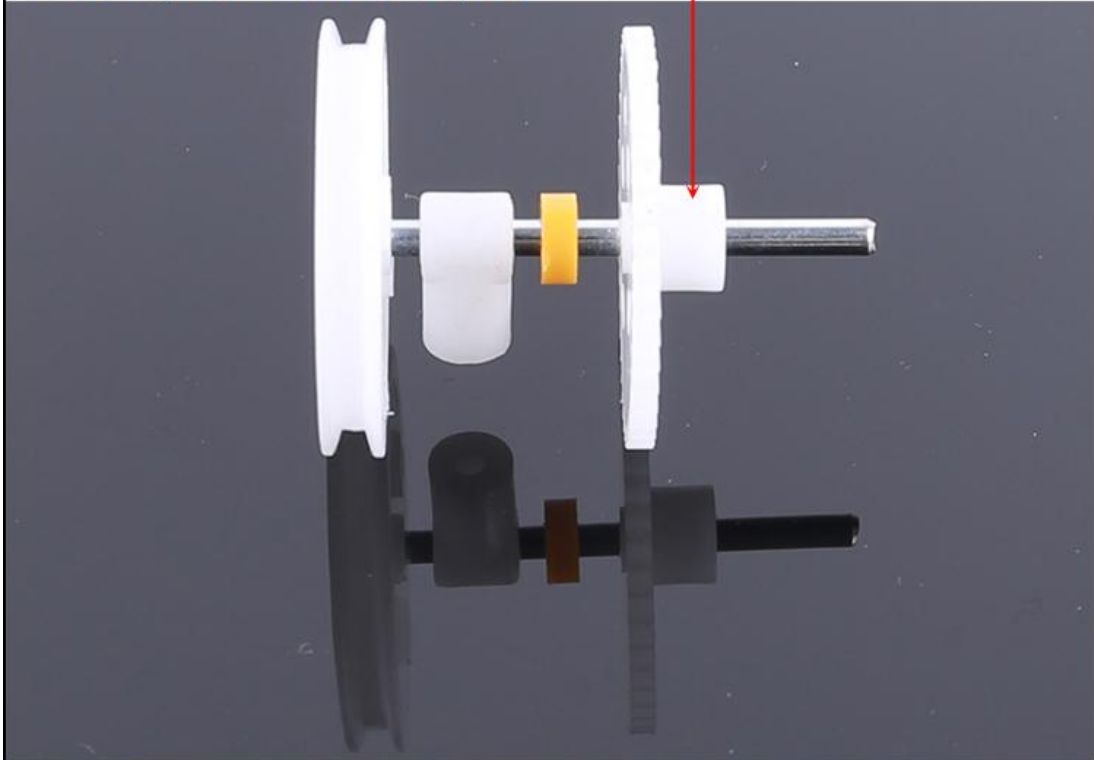

Step 19: Install 1pcs D2.5mm Three-way Sleeve at the end of D2*30mm Axle.

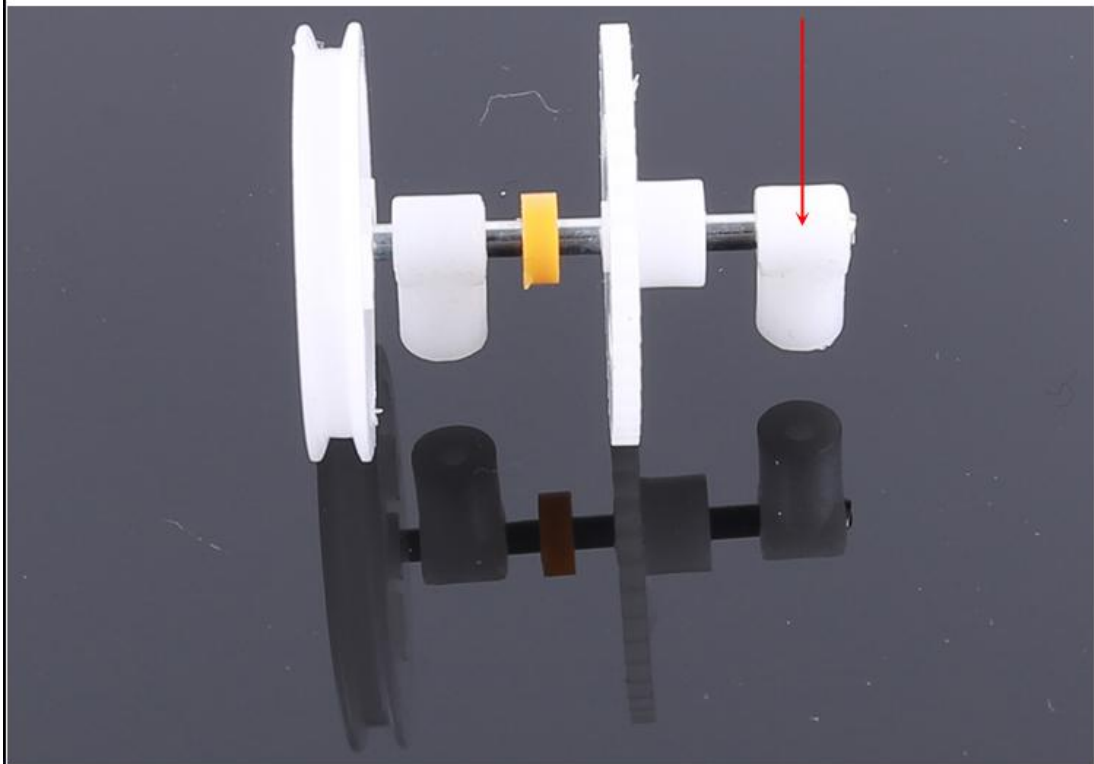

Step 20: Install 1pcs D24mm Tires on D24mm Wheel.



Step 21: Assemble another wheel according to Step 15 ~ Step 20.
Step 22: Install and fix 2pcs JD3-100 DC Motor at M1,M2 by 4pcs D1.7*4mm Black Motor Screw. Pay attention to the installation direction of the motor.

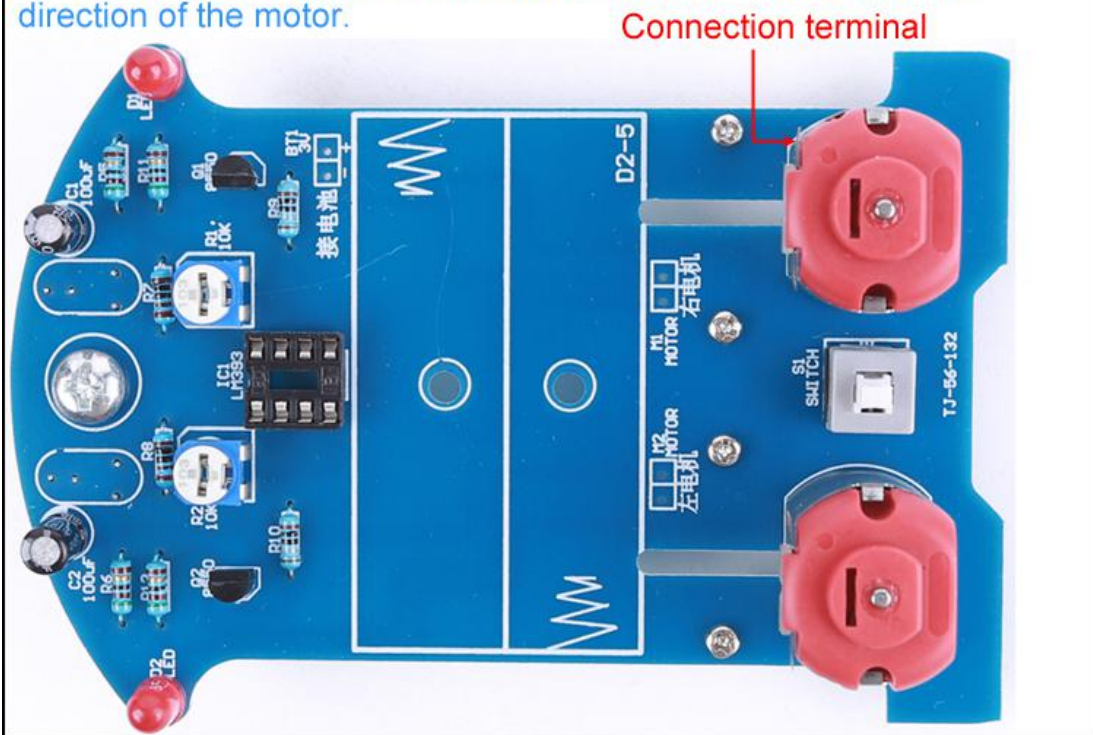

Step 23: Install 2pcs D5mm Worm on motor shaft.

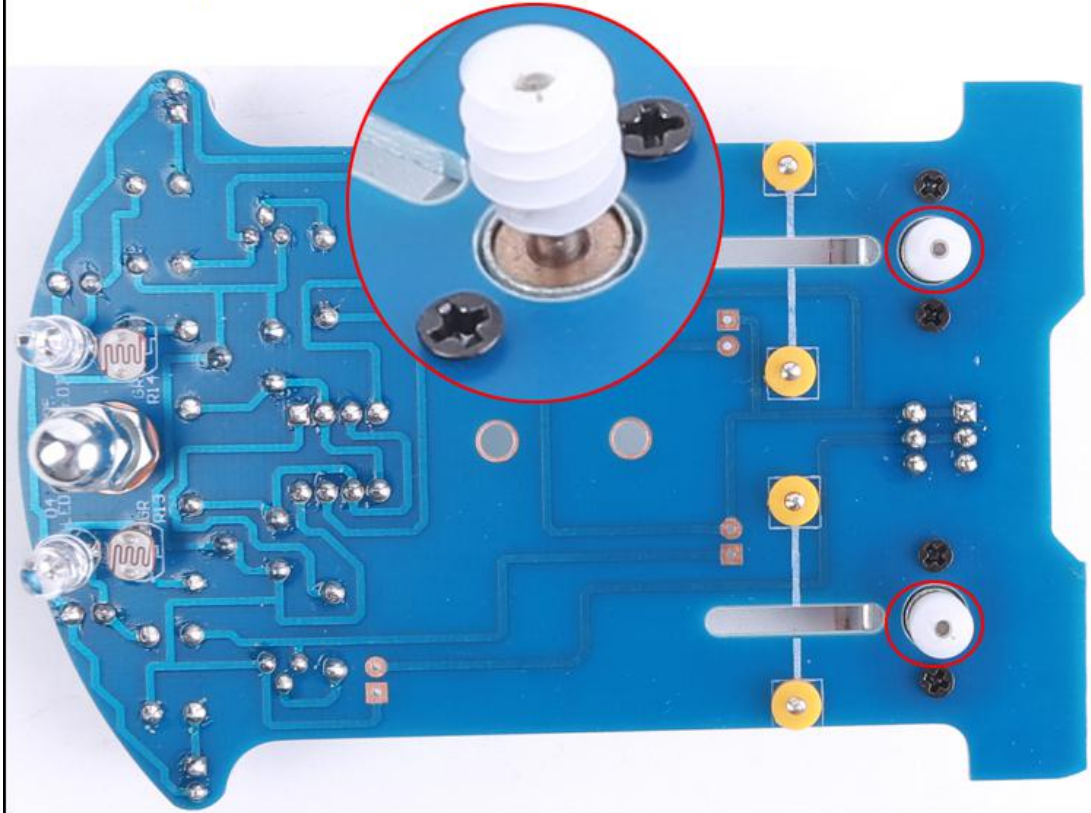

Step 24: Adjust the screw to facilitate subsequent installation.
(That has be install at Step 14)

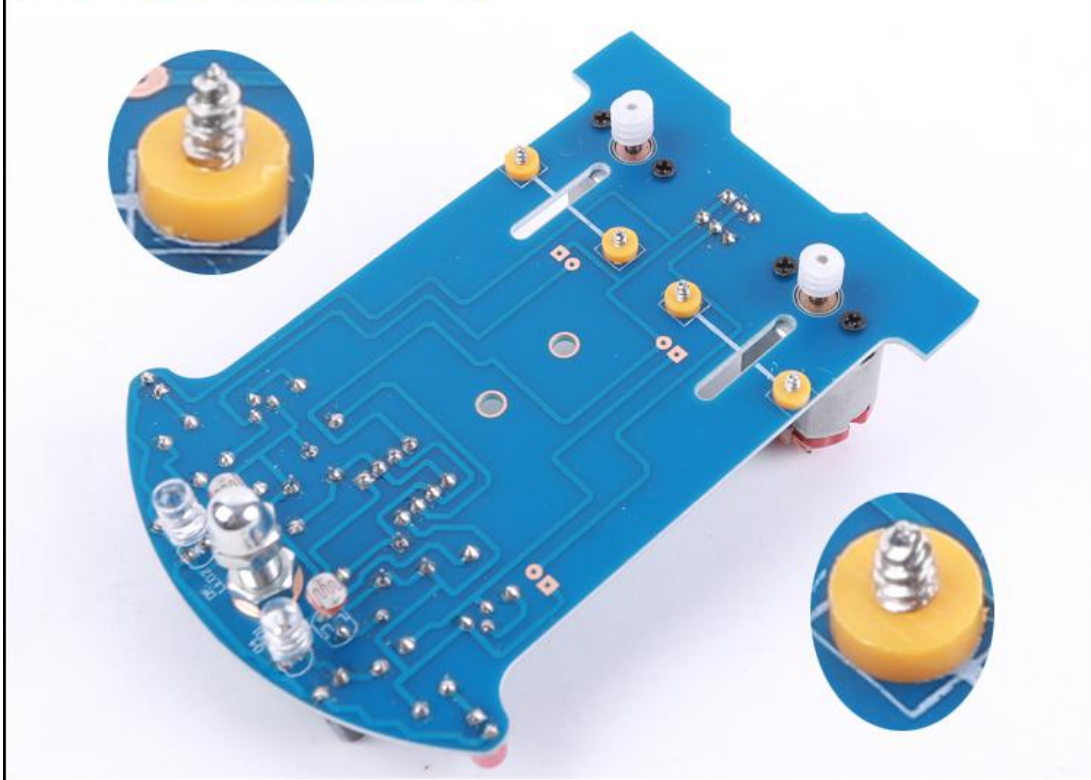

Step 25: Fix the 2pcs assembled wheel on 4pcs D2.0mm Yellow Plastic Spacer. Adjust the distance between the accessories according to the actual situation

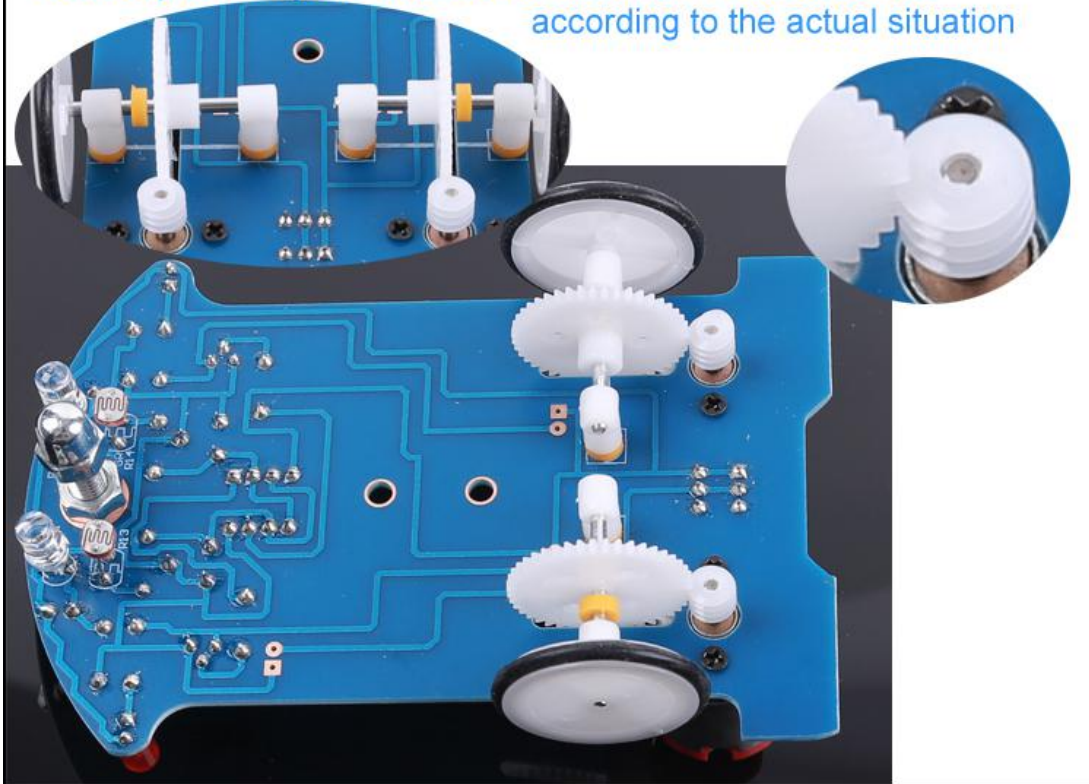

Step 26: Connect 2pcs motor to PCB by 4pcs 6cm cable. Pay attention to the installation sequence of cables and otherwise the trolley may move abnormally.

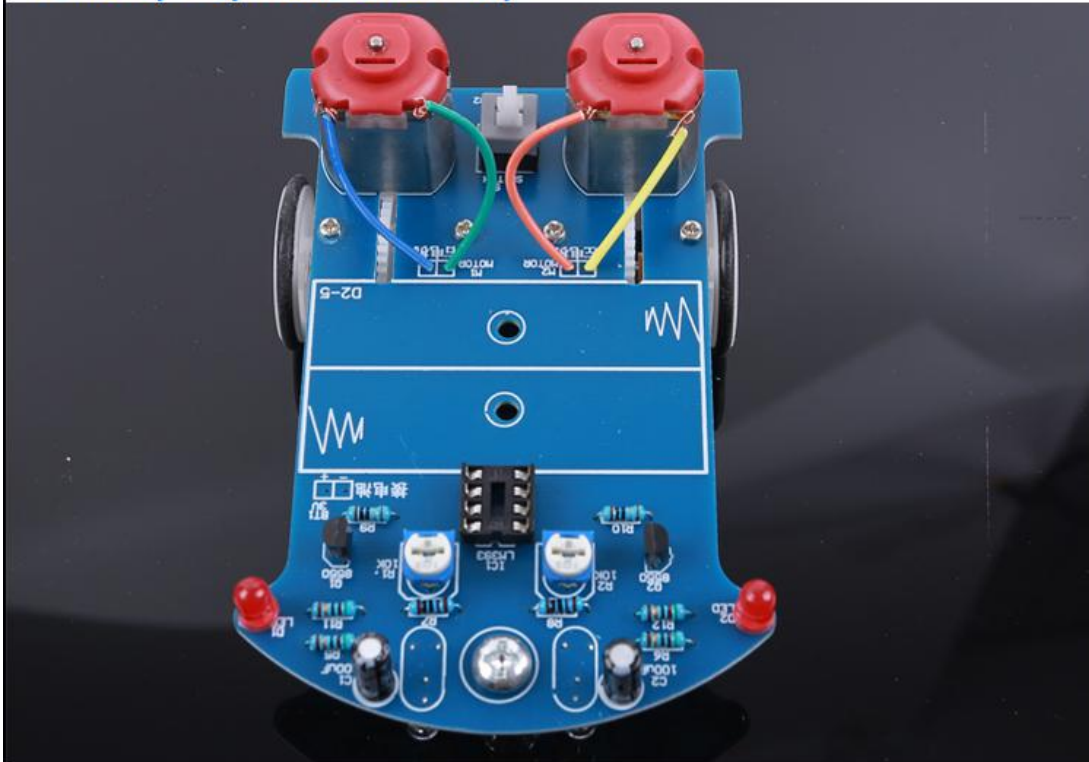

Step 27: Install and fix 1pcs AA*2 Battery Case.



Step 28: Tear off protective film on the back of battery box and then paste the battery box on surface of PCB and pay attention to the wire.

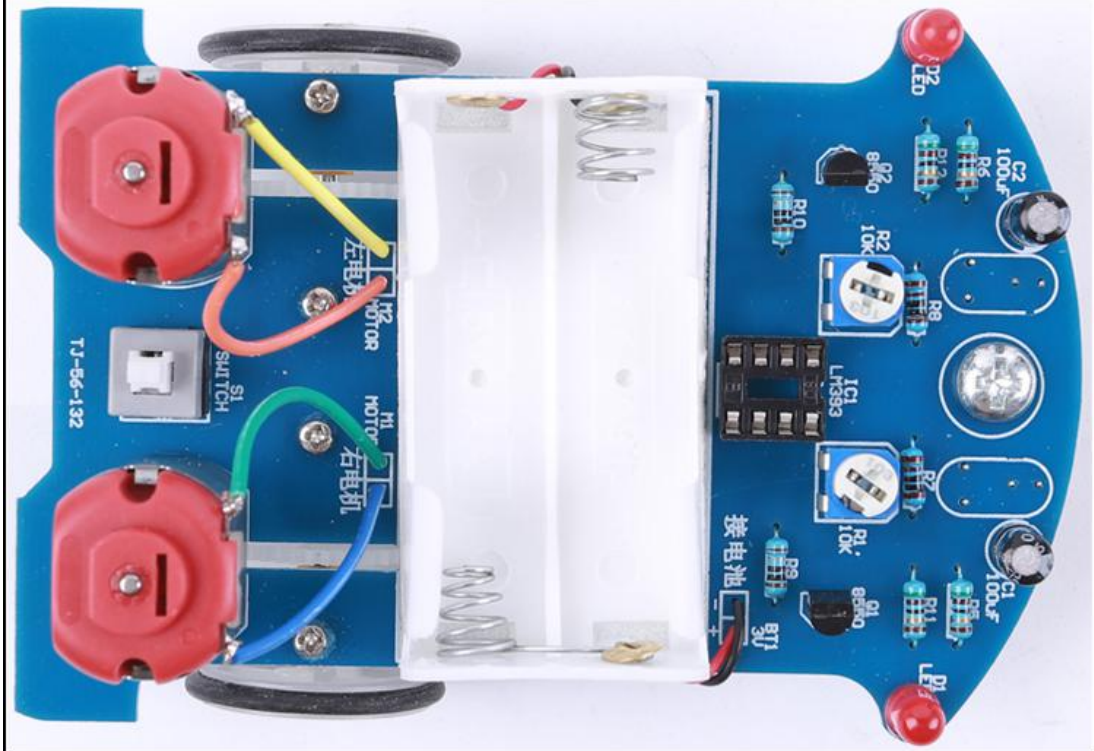

Step 29: Install 1pcs DIP-8 LM393 at IC Socket. There is a mark on one end of the IC and there is a mark on PCB where IC can place on. These two marks are corresponding to each other and are used to

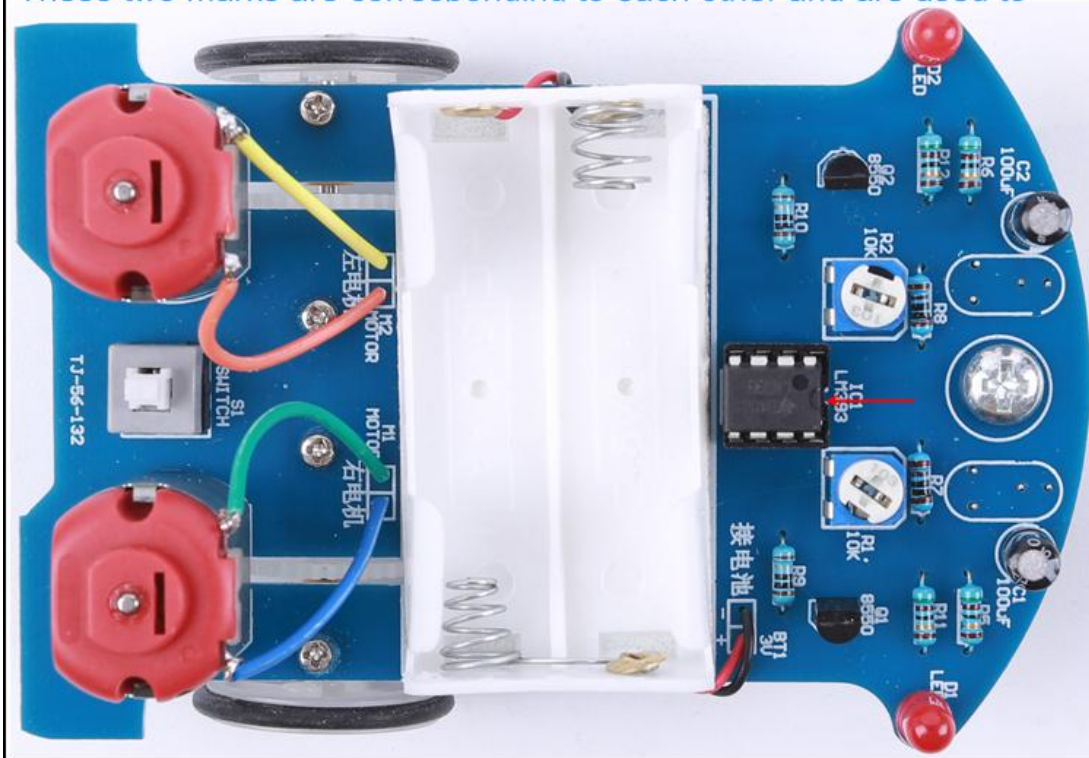

Step 30: Installation Fault debugging:

30.1>.Install 2pcs AA Battery(User need to prepare for themselves)
30.2>.Turn ON switch.It is OK if 2pcs Red LED turn ON.Otherwise, the red LED may be installed incorrectly.

30.3>.The connection sequence of the motor wires needs to be exchanged if the rotation direction of the motor is wrong.

30.4>.The adjusting potentiometer is used to change the detection distance of the photosensitive sensor.

Step 31: Connect to power supply and enjoy the effect.

